

GEISSELE[®]

AUTOMATICS

We Manufacture Confidence[®]

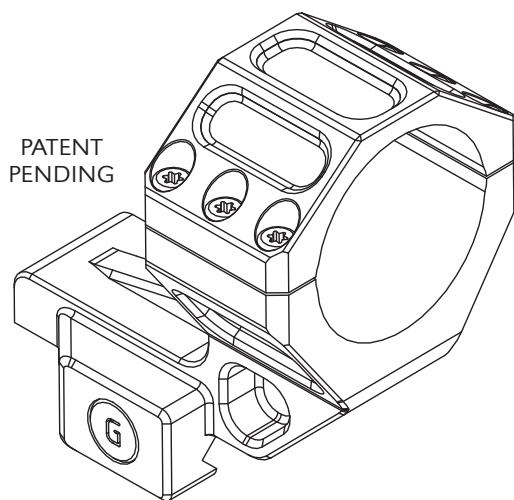

SUPER PRECISION[®]

AIMPOINT PRO SCOPE MOUNT

INSTALLATION INSTRUCTIONS

READ THIS FIRST

Firearm safety is **YOUR** responsibility. You must memorize and put into practice the 4 Rules of Firearm Safety:

- 1. ASSUME EVERY WEAPON IS LOADED.**
- 2. KEEP YOUR FINGER OFF THE TRIGGER UNTIL YOU ARE READY TO SHOOT.**
- 3. DO NOT LET THE MUZZLE POINT AT ANYTHING YOU ARE NOT WILLING TO DESTROY.**
- 4. KNOW YOUR TARGET AND WHAT IS BEYOND.**

A BRIEF DESCRIPTION OF GEISSELE'S SUPER PRECISION SCOPE MOUNTS

A U.S. D.O.D. customer asked Geissele to make them an ultra high quality, bomb proof scope mounting system that met their mission critical return to zero requirements.

Machined from a single 4.5 pound block of aircraft grade 7075 -T6 billet aluminum, the Super Precision Scope Mount is milled down to an ultra light 7.2 ounces (*depending on scope mount model*). This Geissele Super Precision Scope Mount features three precision machined shear lugs so that the optic stays in place during recoil and bolt carrier counter recoil.

The Geissele mounts are locked in place utilizing the classic, battle proven nut and clamp system which provides 1,400 pounds of clamping force per nut. This system provides up to 3 times more clamping force than any lever system.

PACKAGE CONTENTS

- Super Precision Mount
- Scope cap retaining screws (6)
- Instruction Sheet & Drawing

ADDITIONAL TOOLS REQUIRED

- T15 Star Hex Key Screwdriver
- ½" wrench
- Method of securely supporting rifle
- Optional: Torque wrench in inch-pounds increments and foot-pound increments

INITIAL ASSEMBLY

1. The assembly process can be accomplished much faster and easier when the rifle is firmly supported. If working on an AR style rifle the Geissele Reaction Rod is the perfect solution for providing this support to the upper receiver.
2. With the rifle well supported, install the scope mount to the Picatinny rail. The clamping interface along with the three closely toleranced shear lugs will provide a snug and repeatable connection between the rail and mount. Due to this close fit, any finish on the rail slots that add build up, such as paints or ceramic-based coatings, might cause interference. If these finishes are present they may need to be trimmed with a razor blade. Until the final eye-relief is set, the clamping nuts can be tightened by hand (**FIGURE 1**).

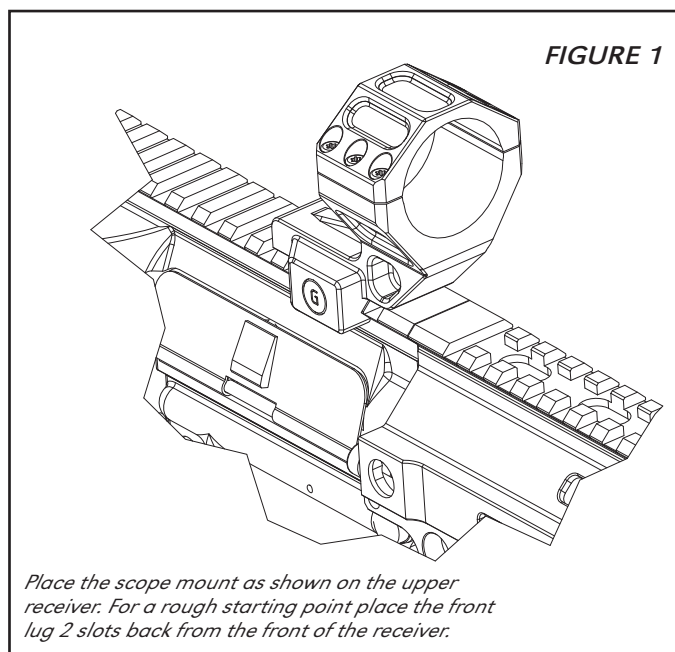

3. Next, the optic can be placed in the ring. The scope should drop in with little to no pressure but feel solid in the mount. If the scope does not drop in, or is too loose, stop and confirm the sizing of the mount and optic.
4. With the scope roughly located in the rings, attach the caps and start the screws into the base.
5. At this time it is best to set eye relief and check for reticle cant. It is good practice to set eye relief in the prone position and with a magnifier in place if it will be used.

6. After a final check of reticle alignment and eye relief, the scope caps can be tightened to their final torqued value. The six screws which hold the cap together should be tightened in an 'X' pattern. Take care to make sure the gaps on either side are kept even (FIGURE 2). The screws can be torqued tight using a T15 star hex key screwdriver. Alternately, if the user would like to use a torque wrench, the final torque value should be 15-18 inch-pounds (Figure 3).

NOTE: It is not recommended to use thread locker (Loctite) on the cap screws. We have found that they will remain in place and stay tightened during use. However, if thread locker is used, it can only be Loctite 222 Purple. **Do Not Use Blue or Red versions.**

7. The final step is to tighten the clamping nuts on the mount to the rifle. This can be completed using a 1/2" box-end wrench. Final torque is reached when the wrench is 1/4 turn past hand tight. If using a torque wrench is preferred, the torque value should not exceed 6 foot-pounds or 72 inch-pounds to prevent damage to the receiver. Note, if removing and re-installing in the field is required; a torque wrench is not necessary. Any method of attaching the mount, such as pliers or a wrench, will be sufficient for returning to the optic's zero.

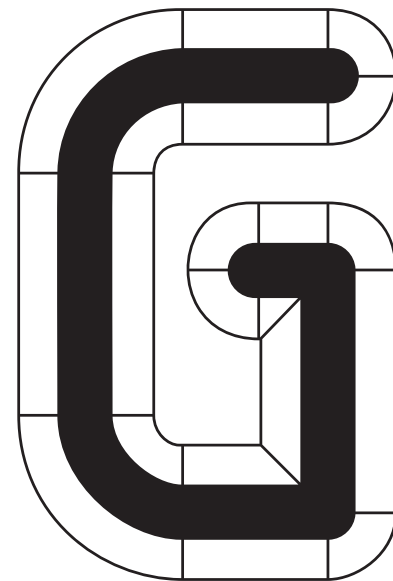
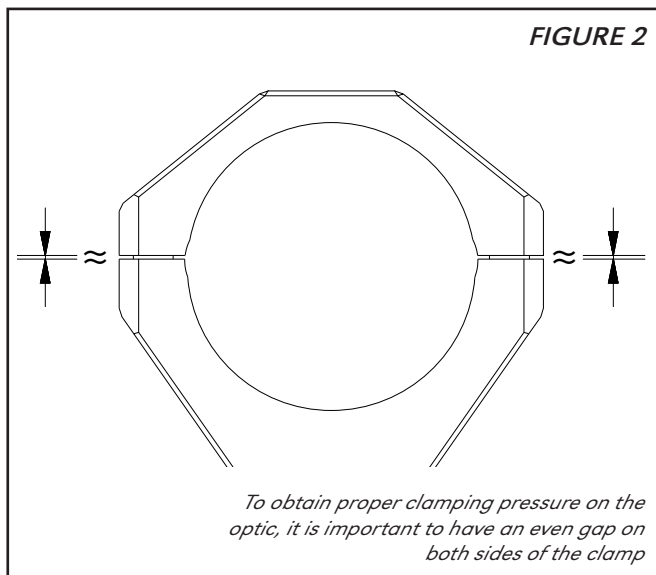
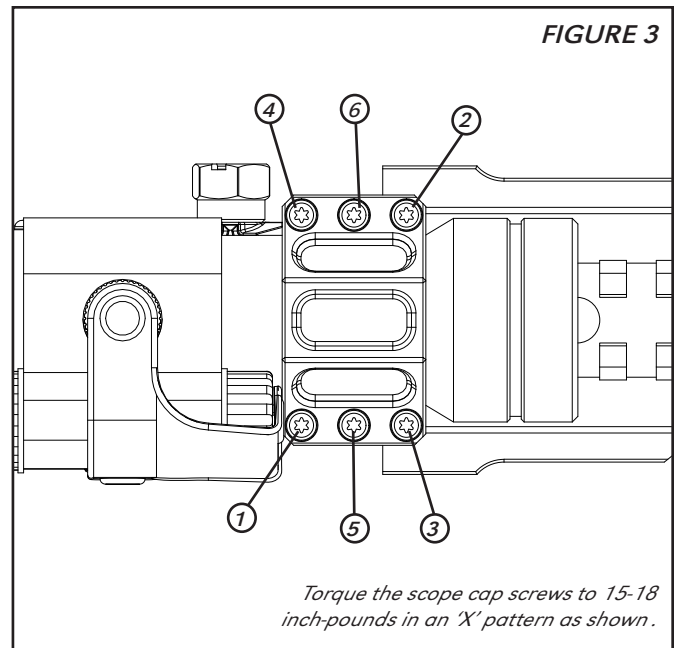

Thank You For Your Purchase.
Contact Geissele Automatics with any questions.

GEISSELE AUTOMATICS • 800 North Wales Road • North Wales, PA 19454
TEL: 610.272.2060 | **FAX:** 610.272.2069
E-MAIL: sales@geissele.com | **WEB:** www.geissele.com