

OPERATOR'S

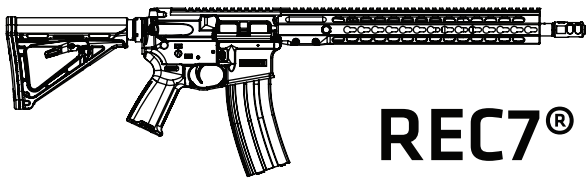

REC7[®] DI
OPERATOR'S MANUAL



TABLE OF CONTENTS

2	USE OF THIS MANUAL
2	SAFETY GUIDELINES
4	WARRANTY AND SERVICE
5	NOTES
6	FUNCTIONS AND FEATURES
6	BREAK-IN PROCEDURE
6	LOADING
8	FIRING
8	UNLOADING AND CLEARING
10	DISASSEMBLY AND ASSEMBLY
11	SEPARATING THE UPPER AND LOWER ASSEMBLIES
12	DISASSEMBLY OF UPPER RECEIVER COMPONENTS
12	DISASSEMBLY OF BOLT CARRIER
13	BOLT DISASSEMBLY
13	DISASSEMBLY OF LOWER RECEIVER
15	CLEANING AND LUBRICATION
18	TROUBLESHOOTING
20	EXPLODED VIEW
22	PARTS LIST

USE OF THIS MANUAL

Read this manual before you use or manipulate your Barrett product. It is important that you understand the principles of safe gun handling in general and the features of this product. This manual is not a substitute for training from a qualified instructor. Important safety topics are discussed in this chapter and throughout this manual. This manual should remain with the product and it should be transferred with the product to subsequent owners. Additional manuals can be ordered from Barrett Firearms Manufacturing or can be downloaded from the company website, **barrett.net**. Technical specifications are subject to change without notice. Please ensure you have the most updated revision of this manual by checking **barrett.net**. The revision letter can be found on the back of this manual.

SAFETY GUIDELINES

WARNING

**FAILURE TO FOLLOW SAFETY GUIDELINES
MAY CAUSE INJURY OR DEATH**

AMMUNITION

Do not use hand loaded, re-manufactured, or surplus ammunition. Always use new, clean, dry, properly stored, and correct caliber ammunition from reputable manufacturers.

SAFETY DISTANCE

Bullets fired from this rifle may travel as far as 4 miles. Make certain that you have an adequate backstop.

HEARING PROTECTION

Always wear adequate hearing protection when the rifle is firing; wear both earplugs and shooting muffs together for maximum protection. This includes observers. Observers should always be behind the shooter.

EYE PROTECTION

Appropriate eye protection should be worn when both shooting and maintaining your rifle. It is normal for firing to generate airborne dust and debris. Protect your eyes from solvents and uncaptured parts under spring pressure while performing maintenance on your rifle.

MUZZLE CONTROL

Always keep the muzzle pointed in a safe direction. Never allow your muzzle to point at anything that you do not intend to shoot. Upon firing the muzzle brake releases high-pressure gas from its side ports that can damage objects or cause injuries, keep everything away from the vicinity of the muzzle brake.

ASSUME EVERY GUN IS LOADED

Always treat every gun as if it were loaded. Look and feel for an empty chamber. Do not trust the extractor to provide an empty chamber.

BEWARE OF BARREL OBSTRUCTIONS

Ensure the barrel's bore is free of obstructions before you fire your rifle. Even the smallest obstruction such as a stuck patch or even grease will cause increased pressures that can rupture the barrel.

KEEP YOUR FINGER OFF THE TRIGGER

Keep your finger off the trigger and out of the trigger guard until your sights are aligned on your target and you intend to fire.

KEEP YOUR SAFETY ON

Keep your safety on until your sights are aligned on your target and you intend to fire. Please note that the safety lever will not rotate into the "SAFE" position until the bolt is open or the action is cocked.

FAILURE TO FIRE

If your rifle fails to fire when you pull the trigger, do not pull the charging handle. Keep the rifle pointed toward a safe area and wait 2 minutes. If a hang-fire (slow ignition) has occurred, the round will probably fire within two minutes. If the round does not fire, remove and inspect the cartridge. If the primer is indented properly, discard it in a safe manner.

MAINTAIN YOUR RIFLE PROPERLY

Performing proper maintenance, as outlined in this manual, insures that your rifle will be safe to shoot and will perform to design specification for many years. Alterations, modifications or

adjustments may damage your rifle, make it unsafe to fire and will void warranty claims.

STORE YOUR RIFLE SAFELY

It is your responsibility to take reasonable precaution to secure your rifle, keep it properly secured and prevent unauthorized use.

ALCOHOL, MEDICATIONS AND DRUGS

Do not handle or operate your rifle under the influence of alcohol, medication or drugs.

WARRANTY AND SERVICE

For one year from date of purchase, Barrett Firearms Manufacturing Inc. (BFMI), warrants to the original owner, that this product was manufactured free of defects in materials and workmanship. BFMI will correct any defect covered under the warranty by repair or replacement with the same or comparable model. BFMI will not be responsible for injury, death, or damage to property resulting from either intentional or accidental discharge of this firearm or from its function when used for purposes or subjected to treatment for which it was not designed. BFMI will not honor claims involving this product which result from careless or improper handling, unauthorized adjustment or parts replacement, corrosion, neglect, the use of the wrong caliber ammunition, or the use of other than commercially manufactured ammunition in good condition, or any combination thereof. Please visit **barrett.net** for any additional information.

If you need factory service, whether covered under warranty or not, please contact BFMI for instructions on how to have your rifle repaired.

Barrett Firearms Manufacturing Inc.
P.O. Box 1077
Murfreesboro, TN 37133-1077
615-896-2938

FUNCTIONS AND FEATURES

- The REC7 is a lightweight, semi-automatic, magazine-fed, air cooled rifle with a rotating bolt actuated by direct gas impingement.
- User-selected accessories may be mounted on Mil-Std 1913 top rail.
- Side and bottom areas of the Barrett handguard offers several positions for mounting rail sections or accessories.

BREAK-IN PROCEDURE

Barrett does not offer a specific procedure for barrel break-in other than checking for obstructions and using your new rifle.

Experience has shown that the bore becomes less prone to fouling over time and that accuracy may improve with use. Ensure that the rifle is adequately lubricated and follow the loading/unloading and safety procedures when operating your rifle.

LOADING

⚠ WARNING

POINT MUZZLE IN A SAFE DIRECTION.

1. Insert a loaded magazine fully into the magazine well. Insert the magazine until the magazine catch engages and holds the magazine. Tap the magazine upward to ensure the magazine is fully seated, then pull down on the magazine to ensure proper retention (**FIGURE 1**).

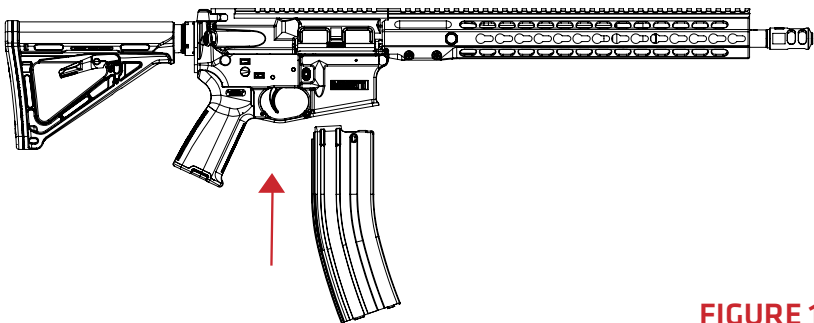
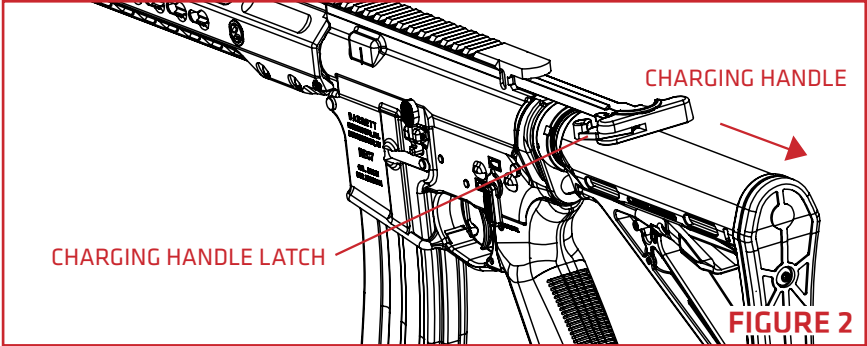
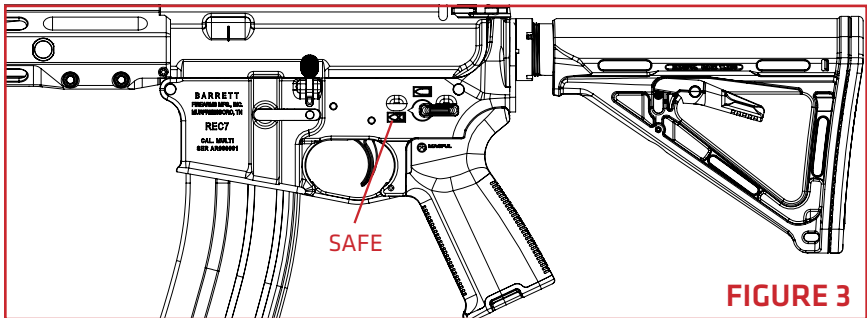

FIGURE 1

2. Before pulling the charging handle, disengage the charging handle latch with index finger on left side of handle. Pull charging handle back with thumb and index fingers. Once the charging handle is in the rearward most position, release handle with both fingers and let the handle go forward without any assistance. This will ensure the full force of the buffer spring is utilized to chamber the first round (**FIGURE 2**).



3. Place safety selector switch to SAFE position until ready to operate (**FIGURE 3**).



NOTE: THE HAMMER MUST BE COCKED IN ORDER FOR THE SELECTOR TO BE PLACED ON "SAFE".

FIRING

Move the selector switch to FIRE to enable trigger movement (**FIGURE 4**).

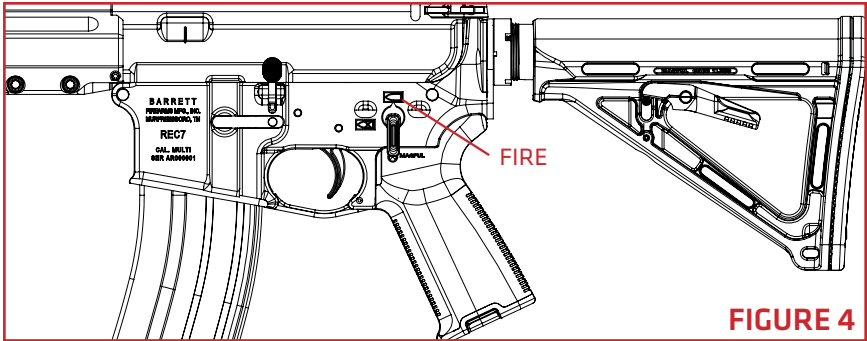

UNLOADING AND CLEARING

1. Place the selector switch on SAFE (**FIGURE 5**).

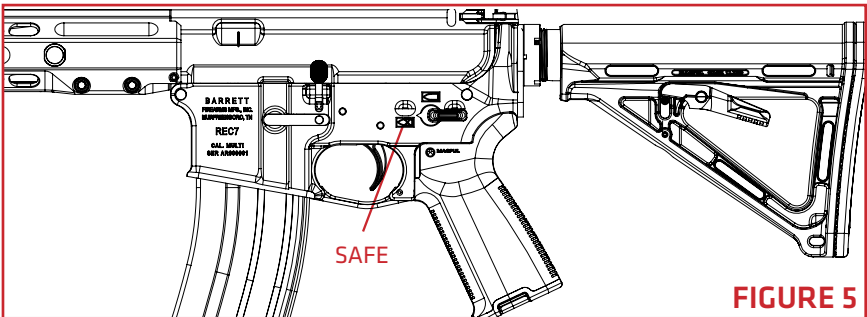

2. Remove the magazine by depressing the magazine release button and allowing it to fall free (**FIGURE 6**).

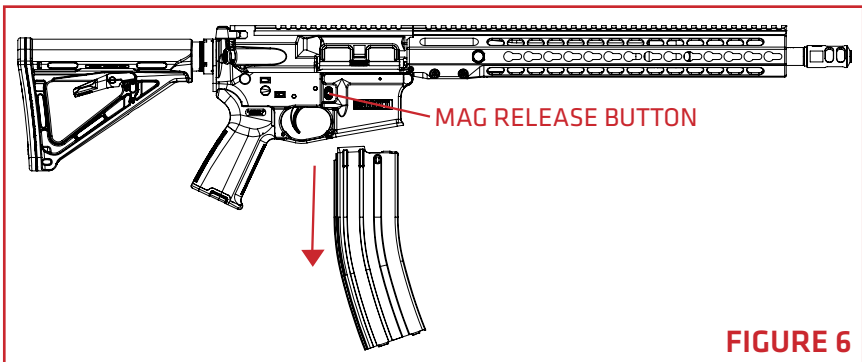

- To lock the bolt open, pull the charging handle rearward to hold the bolt carrier to the rear (**FIGURE 7-A**). While holding the charging handle rearward, depress the bottom of the bolt catch (**FIGURE 7-B**). Release tension on the charging handle and ensure the bolt is held open. Push the charging handle forward until it latches (**FIGURE 7-C**).

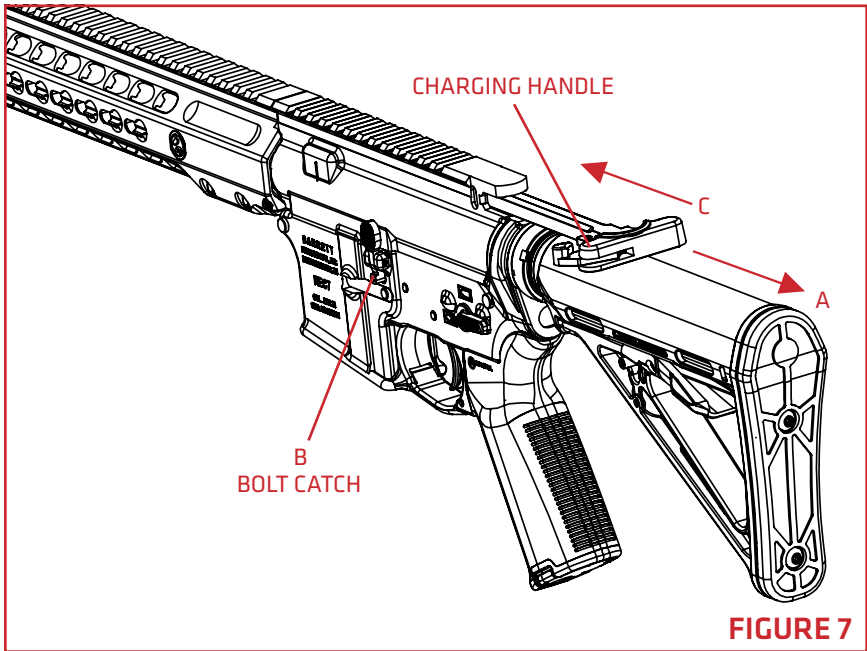

4. Use caution by visually and physically inspecting the chamber and magazine well to ensure that it is empty (**FIGURE 8**).

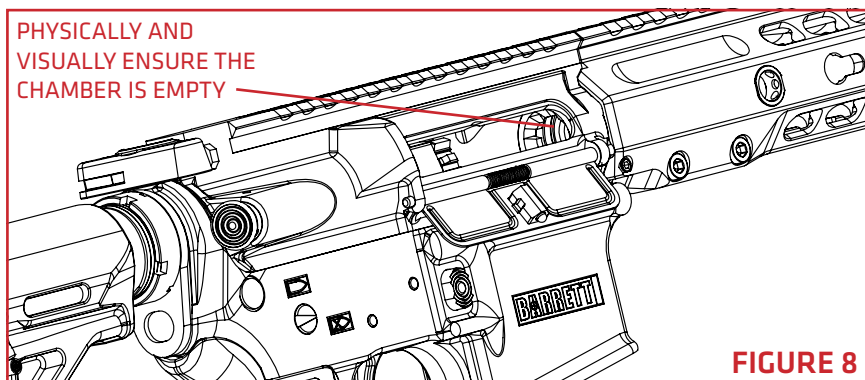

5. Place the selector switch on SAFE (**FIGURE 9**). Press the upper portion of the bolt catch to allow the bolt assembly to close. Repeat steps 3-5 to ensure rifle is unloaded and cleared.

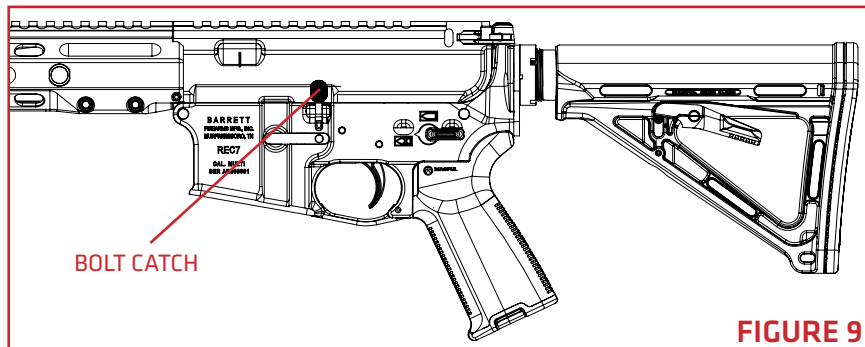

DISASSEMBLY AND ASSEMBLY

This rifle separates into two primary assemblies:

1. The upper assembly (**FIGURE 10-1**).

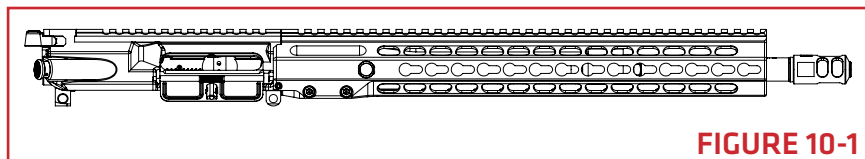

2. The lower assembly (**FIGURE 10-2**).

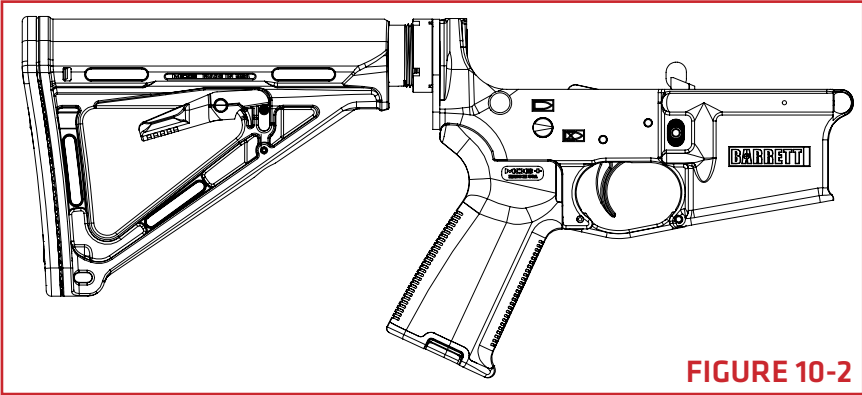

FIGURE 10-2

SEPARATING THE UPPER AND LOWER ASSEMBLIES

1. Ensure rifle is unloaded and clear by following the steps in the previous section. With the safety on and bolt closed, push the take down pin (rear most pin) until it clears its detent and stops (**FIGURE 11**). Take down and pivot pins are captured and cannot be removed. Push the pivot pin (forward most pin) until it clears its detent and stops. Separate the upper and lower receivers.

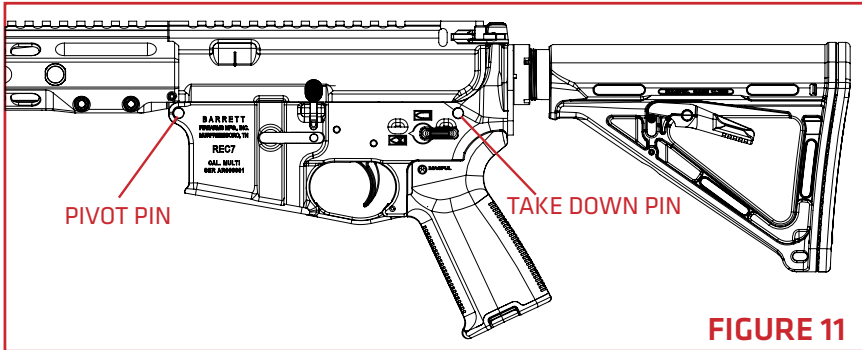

FIGURE 11

DISASSEMBLY OF UPPER RECEIVER COMPONENTS

1. Pull back the charging handle and withdraw the bolt carrier assembly (**FIGURE 12**).
2. Lift the charging handle out of its track and remove it.

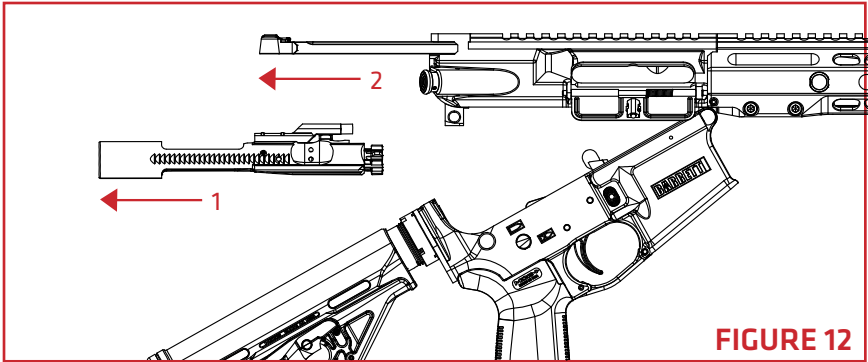

FIGURE 12

DISASSEMBLY OF THE BOLT CARRIER

1. Remove the firing pin retaining pin from the bolt carrier. Gently push or pull the pin out of the bolt carrier.
2. Remove the firing pin from the bolt carrier. Using a clean soft surface, lightly strike the rear of the bolt carrier to assist in removal. (Never use a sharp object to push the firing pin out of the bolt)
3. To remove cam pin, rotate cam pin 90 degrees and push the bolt into the bolt carrier. Cam pin should extract by hand.
4. Remove bolt assembly from the bolt carrier.

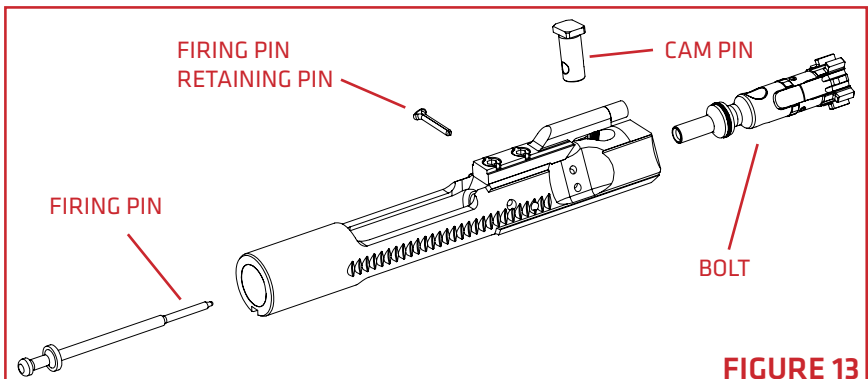
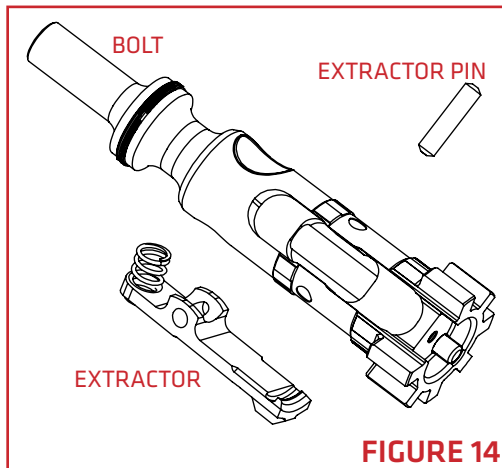

FIGURE 13

BOLT DISASSEMBLY

NOTE: DISASSEMBLY OF THE EXTRACTOR SPRING AND INSERT FROM THE EXTRACTOR ASSEMBLY IS NOT REQUIRED FOR REGULAR CLEANING AND IS NOT RECOMMENDED. DISASSEMBLE ONLY WHEN EXCESSIVE DEBRIS PREVENTS NORMAL OPERATION OR PARTS ARE DAMAGED.

1. Use a pin punch to remove the extractor pin. Applying pressure to the rear of the extractor directly above the extractor spring will aid in removal of extractor pin. Be aware that the extractor spring and extractor are under compression.
2. Remove the extractor assembly (**FIGURE 14**).
3. Further disassembly of the bolt is not necessary for field maintenance.



DISASSEMBLY OF LOWER RECEIVER

⚠ CAUTION

THE DISASSEMBLY OF TRIGGER COMPONENTS SHOULD BE ACCOMPLISHED BY A QUALIFIED ARMORER.

⚠ CAUTION

THE BUFFER RETAINER IS UNDER STRONG SPRING PRESSURE. IF NOT PROPERLY RETAINED, IT CAN BE LAUNCHED FROM ITS TUBE AND CAUSE INJURY.

NOTE: DO NOT PULL TRIGGER WHILE LOWER IS DISASSEMBLED FROM THE UPPER. THE HAMMER WILL STRIKE THE RECEIVER AND MAY DAMAGE OR BREAK THE RECEIVER AND/OR BOLT CATCH.

1. Push on the buffer face with finger pressure while holding the retainer down with a suitable tool (**FIGURE 15-1**). Carefully remove the buffer and spring assembly (**FIGURE 15-2**).

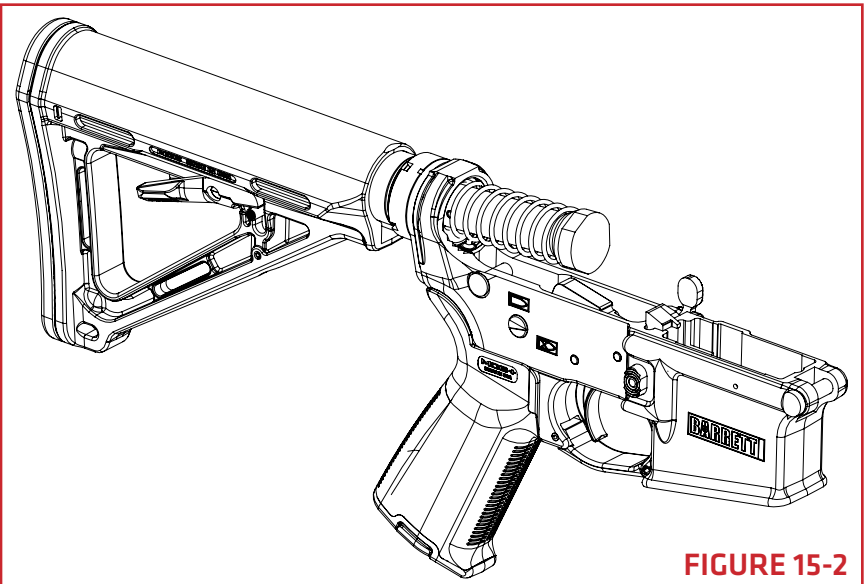
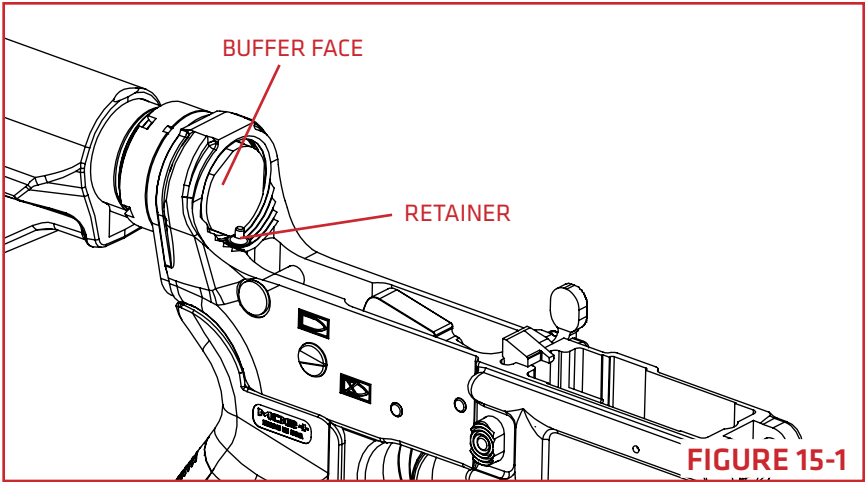

CLEANING AND LUBRICATION

⚠ WARNING

UNLOAD AND CLEAR THE RIFLE BEFORE CLEANING.

⚠ CAUTION

DO NOT INSERT CLEANING RODS THROUGH MUZZLE. THE BARREL CROWN COULD BE DAMAGED WHICH WOULD SEVERELY DEGRADE THE ACCURACY OF THE RIFLE.

⚠ CAUTION

EYE PROTECTION IS RECOMMENDED WHILE CLEANING.

CLEANING PROCEDURE

The rifle should be cleaned and lubricated after each shooting session.

1. Apply cleaning solvent to a chamber brush and clean the chamber.
2. Apply cleaning solvent to a bore brush and clean the bore. Barrett Heavy Bore Cleaner is recommended. Clean bore from the chamber end of barrel to prevent damage to the muzzle.
3. Clean the muzzle device with a stiff plastic brush and bore solvent. It is best to clean the muzzle device at the same time the barrel is being cleaned as the bore solvent will help loosen carbon build-up on its interior walls.
4. Clean the bolt face with bore solvent. Use a stiff plastic brush to remove debris from both the extractor and the ejector. Depress the ejector and extractor by hand to test their smooth function.
5. Use dry patches as necessary to remove cleaner from the bore and chamber.

6. Clean the remainder of the rifle with cotton-tipped swabs, general purpose brushes and cleaning cloths.

LUBRICATION POINTS (FIGURE 16)

- Do not add lubricant to the interior of the magazine
- Do not lubricate ammunition
- Never store your rifle in a wet carrying case

It is advised to apply a light coat of temperate appropriate lubricant to all functional parts. Recommended lubrication points are in red.

BOLT CARRIER GROUP

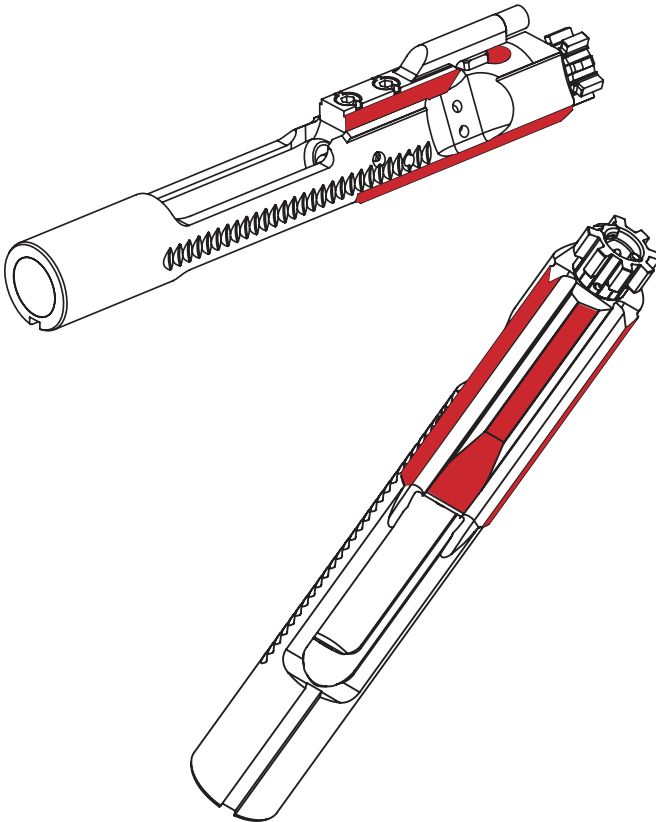

FIGURE 16-1

BOLT

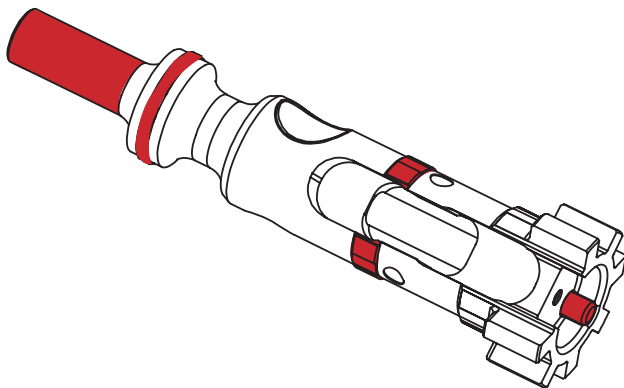

FIGURE 16-2

BUFFER SPRING

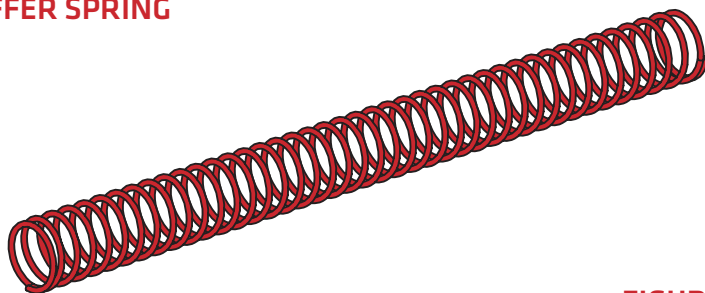

FIGURE 16-3

CHARGING HANDLE

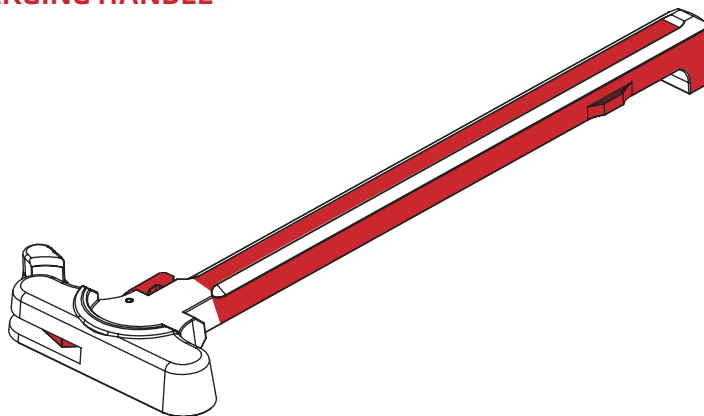

FIGURE 16-4

TROUBLESHOOTING

MALFUNCTION	CAUSE	CORRECTIVE ACTION
FAILURE TO FEED	Did not draw bolt carrier fully to rear	Retract bolt carrier fully to the rear
	Magazine not seated	Seat magazine
	Damaged magazine	Replace or repair magazine
FAILURE TO CHAMBER	Damaged cartridge	Remove and replace cartridge
	Dirty or obstructed chamber	Clean chamber
FAILURE TO GO INTO OR OUT OF BATTERY	Dislodged primer in barrel extension	Disassemble, clean, replace firing pin if necessary
		Ensure proper installation
FAILURE TO FIRE	Faulty ammunition	Replace ammunition
	Obstructed or damage firing pin	Disassemble and clear obstruction

TROUBLESHOOTING

MALFUNCTION	CAUSE	CORRECTIVE ACTION
FAILURE TO EXTRACT	Broken or worn extractor	Replace extractor
	Broken or worn extractor spring	Replace extractor spring
	Extractor not moving freely	Clean extractor, extractor spring, and recess
	Dirty ammunition or chamber	Clean chamber and insure ammunition is clean
	Broken case rim	Clear chamber
FAILURE TO EJECT	Broken or worn ejector	Replace ejector
	Broken or worn ejector spring	Replace ejector spring
	Ejector not moving freely	Clean ejector, ejector spring, and recess

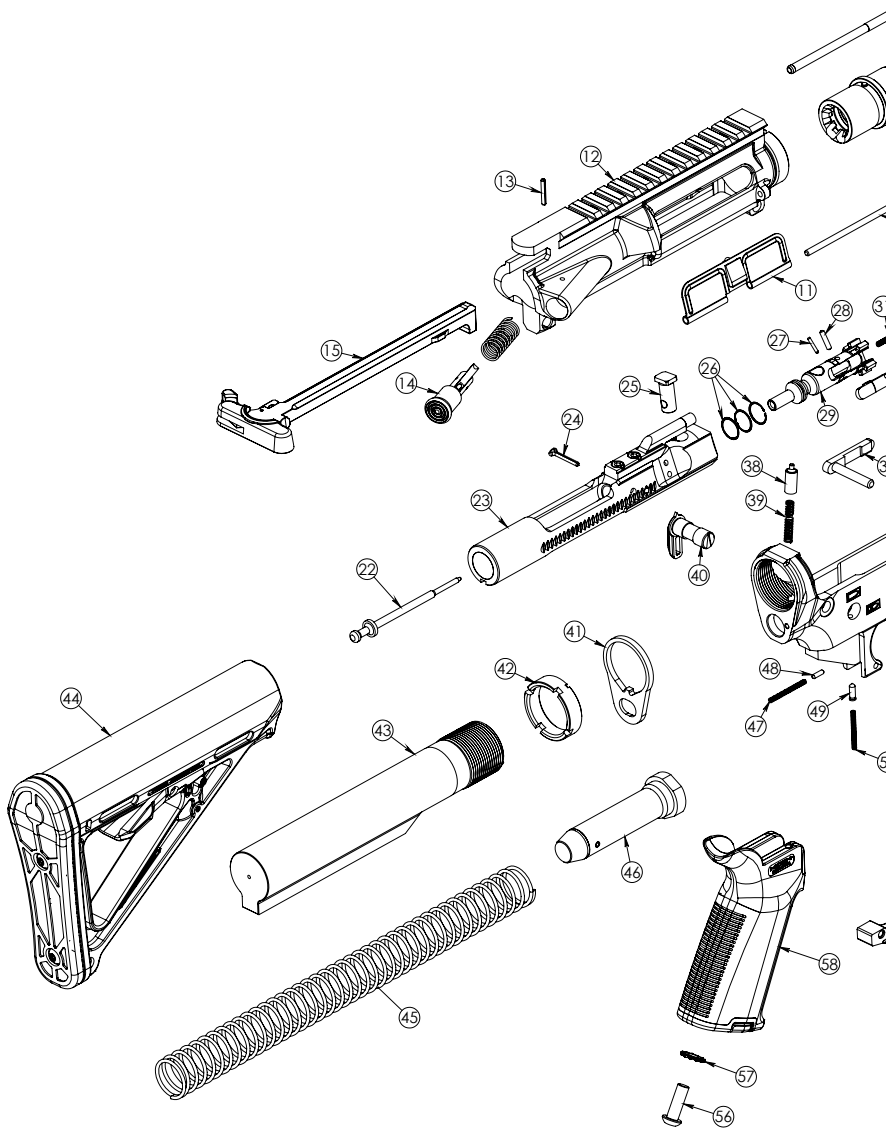

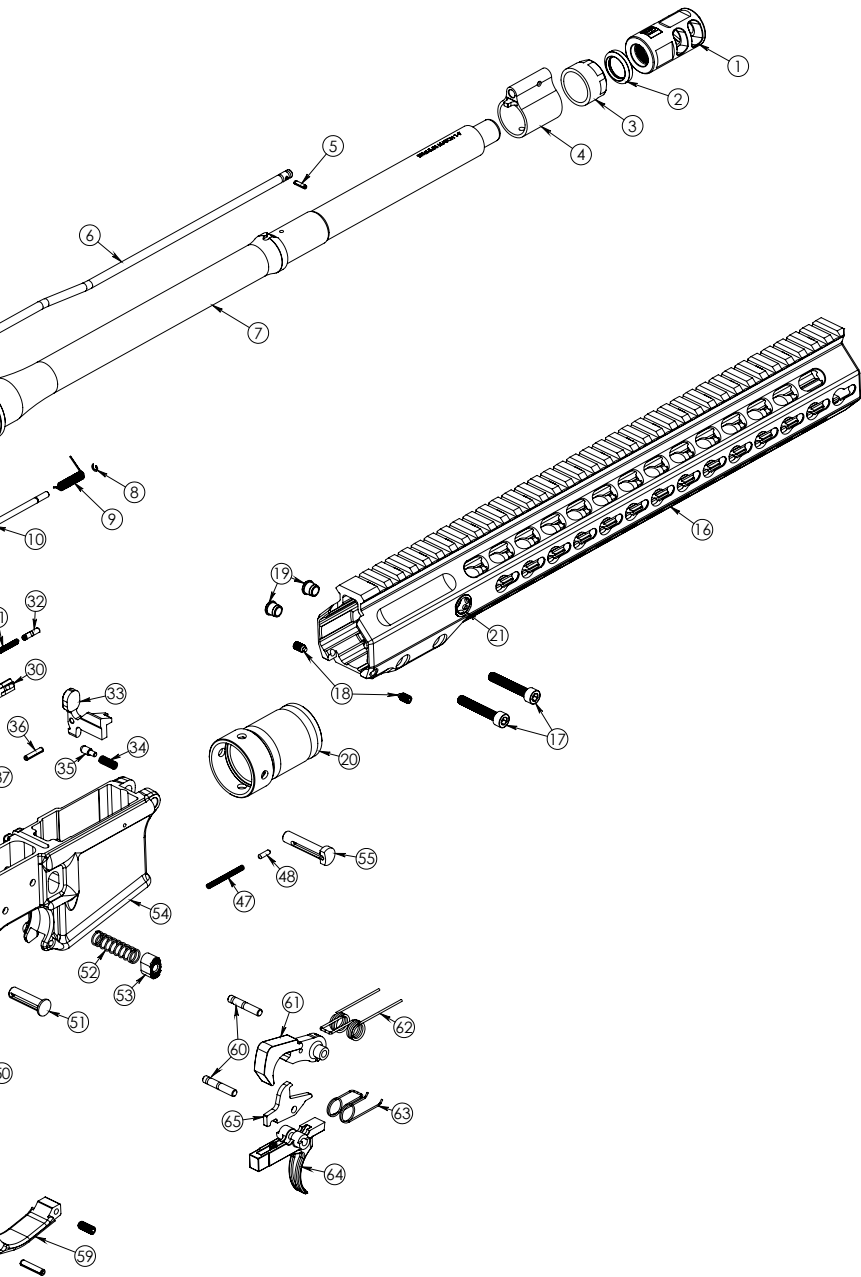

ITEM #	PART DESCRIPTION	QTY
1	MUZZLE BRAKE	1
2	CRUSH WASHER	1
3	GAS BLOCK NUT	1
4	GAS BLOCK	1
5	GAS TUBE RETENTION PIN	1
6	GAS TUBE	1
7	BARREL COMPLETE	1
8	RETAINING CLIP	1
9	EJECTION PORT DOOR SPRING	1
10	EJECTION PORT DOOR PIVOT PIN	1
11	EJECTION PORT DOOR	1
12	UPPER RECEIVER	1
13	FORWARD ASSIST ROLL PIN	1
14	FORWARD ASSIST ASSEMBLY	1
15	CHARGING HANDLE	1
16	HANDGUARD	1
17	HANDGUARD SCREW	2
18	HANDGUARD SET SCREWS	2
19	HANDGUARD BUSHINGS	2
20	BARREL NUT	1
21	HANDGUARD BUSHING	2
22	FIRING PIN	1
23	BOLT CARRIER	1
24	FIRING PIN RETAINING PIN	1
25	CAM PIN	1
26	PISTON RING	3
27	EJECTOR PIN	1
28	EXTRACTOR PIN	1
29	BOLT	1
30	EXTRACTOR	1
31	EJECTOR SPRING	1
32	EJECTOR	1
33	BOLT CATCH	1

ITEM #	PART DESCRIPTION	QTY
34	BOLT CATCH SPRING	1
35	BOLT CATCH PLUNGER	1
36	BOLT CATCH PIN	1
37	MAGAZINE CATCH	1
38	BUFFER RETAINER	1
39	BUFFER RETAINER SPRING	1
40	SAFETY	1
41	RECEIVER END PLATE	1
42	RECEIVER EXTENSION NUT	1
43	RECEIVER EXTENSION	1
44	BUTTSTOCK	1
45	BUFFER SPRING	1
46	BUFFER	1
47	TAKEDOWN DETENT SPRING	2
48	TAKEDOWN DETENT	2
49	SAFETY DETENT	1
50	SAFETY DETENT SPRING	1
51	REAR TAKEDOWN PIN	1
52	MAGAZINE CATCH SPRING	1
53	MAGAZINE RELEASE BUTTON	1
54	LOWER RECEIVER	1
55	FRONT TAKEDOWN PIN	1
56	PISTOL GRIP SCREW	1
57	PISTOL GRIP WASHER	1
58	PISTOL GRIP	1
59	TRIGGER GUARD	1
60	TRIGGER/ HAMMER PIN	2
61	HAMMER	1
62	HAMMER SPRING	1
63	TRIGGER SPRING	1
64	TRIGGER	1
65	DISCONNECTOR	1



P.O. Box 1077
Murfreesboro, TN 37133 USA
615.896.2938
615.896.7313 fax
barrett.net