

SCHMIDT © BENDER

THE NEW EXOS
3-21x50



RELIABLE – NEWLY DEFINED ①

Schmidt & Bender proudly presents the new Exos 3-21x50 rifle scope which is especially designed for crucial hunting and shooting situations. Since over 60 years the German family run company manufactures ultra-high-quality rifle scopes by experienced hunters and shooters, solely committed to quality. Handcrafted reliability, repeatability and intuitive functionality are perfectly combined in this second focal plane, 34mm tube scope. The Exos 3-21x50 is the latest addition to our popular high zooming Exos hunting line.

All scope parts are made of solid, hard anodized aluminum. The tube wall thickness enables the Exos to handle the harshest extremes. The various aluminum parts are chosen carefully in order to meet the tight tolerances necessary for the best quality. The 50mm diameter objective with integrated thread for accessories (sun shade, filter etc) is ideal for mounting the scope as low as possible to the rifle barrel. Night vision, if allowed, and any other accessories can easily be mounted to the scope. The scope is designed and manufactured according to MIL-SPEC 810G. Schmidt & Bender guarantees to have the same production standards for hunting and military scopes alike, one of the reasons for the renowned Schmidt & Bender quality and reliability.

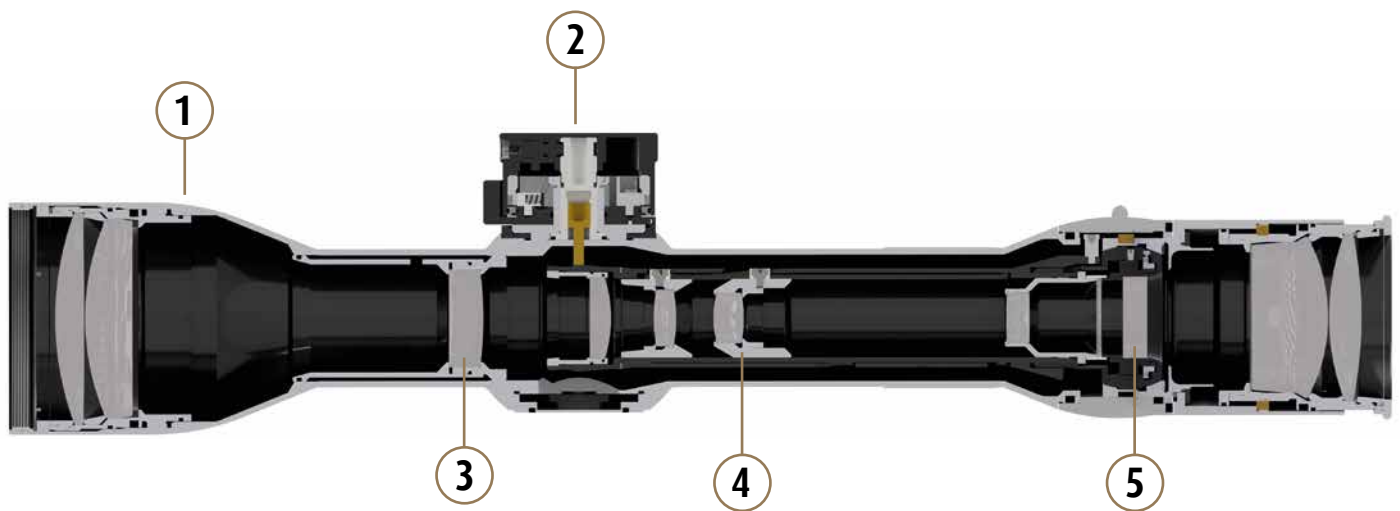

RELIABLE TURRET ADJUSTMENTS “ZERO TOLERANCE CLICKS” ②

One main feature of our new 3-21x50 Exos are the repeatable, robust and temperature resistant elevation and windage turrets. The “Zero Tolerance Clicks” from Schmidt & Bender with either true cm or moa click value are all manually adjusted by our professional technicians. By doing so we guarantee the upmost precise performance. The accurate turret repeatability is ensured by the Schmidt & Bender unique “S-Spring Technology”. With an outstanding elevation travel of 39,5MIL (42MIL internal travel) this scope is perfect for handling anything from a close, quick shot to extreme long range distances. The turrets are designed to be easily operated in extreme temperatures from +70C (158F) to -40C (-40F), even with thick gloves.



RELIABLE PARALLAX ADJUSTMENT ③

The very precise side focus / parallax adjustment begins at 25m/27yd for close distances. It enables the hunter or shooter to estimate distance and to set the parallax accurately in order to avoid aiming errors in the crucial hunting / shooting situations. The robust mechanical engraving can be selected in either meters or yards index.



RELIABLE POINT OF IMPACT DUE TO PATENTED MINIMUM DEVIATION TECHNOLOGY ④

Every second focal plane scope suffers deviation when turning the magnification from maximum to minimum. Our patented "Minimum Deviation Technology" though, enables Schmidt & Bender to have a minimum of deviation in point of impact. The diffractive illuminated reticle in the second focal plane has the smallest deviation of less than 1cm at 100m (0,39" at 109yd), only achievable among premium riflescope manufacturers. This gives the hunter / shooter the most precise point of impact performance even though it is a 7x Zoom second focal plane scope.

RELIABLE ILLUMINATION ⑤

The easy to operate illumination knob has 11 functional steps with "off" positions between each step. An intelligent automatic shut-off sensor turns power off after 6 hours or if the scope is tilted more than 45-degree to the side from vertical line or 70-degree upwards / 110-degree downwards from horizontal line. The illumination restores automatically when moved into firing position. This is extremely advantageous for saving battery life.

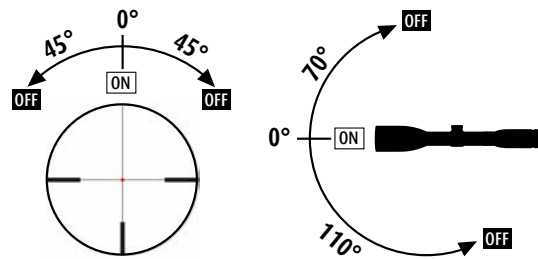

RELIABLE IMAGE QUALITY "TRUE COLOR TECHNOLOGY"

With our new "True Color" optic design our engineers have developed a crystal clear image quality having its emphasis on transmitting a true color image to the human eye. This is extremely important to hunters and shooters who need to exactly identify their target.

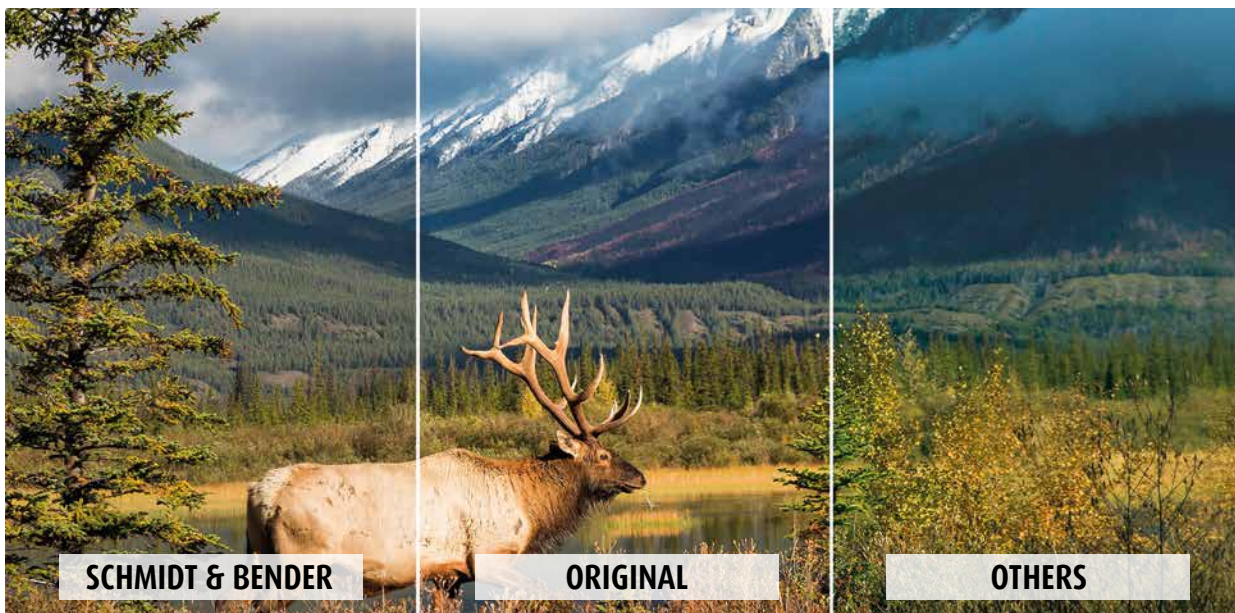

SCHMIDT BENDER

3-21x50 EXOS

1. Dimensions & properties

Weight:	930 g
Length:	343 mm
Main tube diameter:	34 mm

2. Optical Data

Magnification:	3.0 - 21.0
Objective diameter:	50 mm
Field of view:	13.0 m - 1,9 m / 100 m
Exit pupil:	11,4 - 2,4 mm
Eye relief:	90 mm
Twilight factor:	12.3 - 32.4
Transmission:	>90 %
Focal plane:	2.

3. Adjustments

Diopter:	-3 dpt. to +2 dpt.
Elevation range (Single turn):	155 cm / 38 MOA
Elevation range (Double turn):	300 cm / 76 MOA
Windage Range (Single turn):	± 60 cm / ± 15 MOA
Parallax:	25 m - ∞ or 30 yd - ∞

4. Available configurations

a.) Turrets:

Elevation: Single turn / Double turn with locking function

Windage: Single turn with zero stop and capped turret

Turret configurations:

Elevation	Windage
1 cm cw / ccw	1 cm cw / ccw
1/4 MOA cw / ccw	1/4 MOA cw / ccw

b.) Finish: Black

c.) Illumination: Yes (diffractive)

d.) Reticle: D7 (2. focal plane)

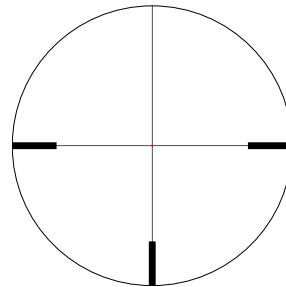

For detailed information about the **NEW EXOS** please visit our website: www.schmidt-bender.com