



# AT308 RIFLE

## USER MANUAL

Accuracy International Ltd.  
Portsmouth. UK.  
Tel + 44 (0) 23 92 67 1225  
Fax + 44 (0) 23 92 69 1852  
Email: [ai@accuracyinternational.org](mailto:ai@accuracyinternational.org)

Accuracy International  
of North America inc.  
Fredericksburg, VA, USA.  
Tel + 1 540 368 3108  
Fax + 1 540 368 3109  
Email: [aina@accuracyinternational.us](mailto:aina@accuracyinternational.us)

[www.accuracyinternational.com](http://www.accuracyinternational.com)

## ACCURACY INTERNATIONAL

Accuracy International was formed in 1978 to design and build tactical rifles.

The original design ethos combined two factors into a unique package. Namely the incorporation of performance enhancing features learned in Olympic and international target shooting onto a platform exhibiting full military ruggedness.

The current designs faithfully follow this original concept, but also benefit from over twenty years of continuous improvement.

These improvements are not cosmetic, but are driven solely by the needs of the users, highly trained military and police units in over 60 countries worldwide.

Such units are exposed to 'live' tactical situations on a daily basis and in the most demanding environments where first shot accuracy is critical.

The rifles are produced in a purpose built 20,000sq. ft. facility in the UK, operating a management system certified to BS EN ISO9001:2008.

All components are manufactured to Accuracy International's designs to ensure that they are optimised for the function they must perform, something that cannot be achieved with a ruggedized-sporting weapon.

The AT308 sniper rifle is an evolution, which builds on Accuracy International's established family of highly successful AW and AX rifles.

A bolt-action single shot rifle with free-floating barrel and a magazine capacity of ten rounds fulfils the need for a highly accurate long range sniper rifle.

Like the AW series, all AT rifles utilise an aluminium chassis system, which ensures insensitivity to temperature and humidity, thus ensuring a constant zero.

The AT rifle is easily upgradeable with a number of accessories and upgrades which can be purchased from Accuracy International distributors.



# CONTENTS

1. SAFETY	4
1.1 SAFETY FEATURES	4
1.2 FIRING PIN COCKING INDICATOR	4
1.3 SAFETY LEVER OPERATION	5
1.4 SAFETY PRECAUTIONS	6
1.5 WARNINGS	7
1.6 SAFETY LEVER - FIELD SAFETY CHECK	7
1.7 CARTRIDGE HEADSPACE	8
2. PARTS IDENTIFICATION	9
3. TECHNICAL SPECIFICATION	9
4. SETTING UP THE RIFLE	10
4.1 BIPOD FITTING AND OPERATION (ACCURACY INTERNATIONAL MODEL)	11
4.2 BIPOD REMOVAL AND REFITTING (HARRIS MODEL)	12
4.3 CHEEK PIECE ADJUSTMENTS	13
4.4 BUTT PAD ADJUSTMENTS	14
4.5 FITTING AND REMOVING ACCESSORY RAILS AND MOUNTS	15
4.6 NIGHT SIGHT BRACKET FITTING AND REMOVAL	16
4.7 REMOVING AND REFITTING THE MUZZLE BRAKE (A.I. MODEL)	17
4.8 FITTING AND REMOVING RAIL MOUNTING PLATES	18
4.9 SCOPE MOUNT ADJUSTMENT	19
5. FOLDING THE STOCK	20
6. FIELD STRIPPING THE RIFLE	21
6.1 STRIPPING THE BOLT ASSEMBLY	22
6.2 MAGAZINE STRIPPING AND REASSEMBLY	23
7. PREPARING AND FIRING THE RIFLE	24
7.1 MAGAZINE LOADING	24
7.2 LOADING THE RIFLE	24
7.3 FIRING AND OPERATING THE RIFLE	25
7.4 RELOADING THE RIFLE	25
7.5 UNLOADING THE RIFLE	26
7.6 FITTING AND REMOVING THE OPTIONAL TACTICAL SUPPRESSOR	27
8. STOPPAGE AND TROUBLESHOOTING DRILLS	28
9. TELESCOPIC SIGHT ADJUSTMENTS	30
9.1 ZEROING THE TELESCOPIC SIGHT	31
10. QUICKLOC BARREL REMOVAL AND REPLACEMENT	32
11. USER LEVEL MAINTENANCE	33
12. BARREL BREAK-IN PROCEDURE	39

# 1. SAFETY

**Before** attempting to use or handle the rifle, this manual must be **read** and **understood fully**. This manual assumes a basic level of user familiarity with firearms and is not a replacement for user training.



**DAMAGE TO PROPERTY, INJURY OR DEATH MAY RESULT IF SAFETY WARNINGS AND INSTRUCTIONS ARE NOT FOLLOWED.**

- Always keep the weapon pointed in a safe direction during handling.
- Never leave a weapon unattended.
- Always wear suitable eye and hearing protection when firing the weapon.
- Always check the barrel, muzzle brake and suppressor, where fitted, are clear of debris and obstructions before firing.
  - Never attempt to clear an obstruction by firing.
- Always use quality factory ammunition of the correct calibre for the weapon.
- Clearly identify your target and what is beyond it.
- When the rifle is loaded, always keep fingers outside of the trigger guard until a shot is to be fired.
- Always show that the weapon is clear before handing it over to another user.

## 1.1 SAFETY FEATURES

- The AT308 rifle bolt utilises six forward locking lugs.
- When the bolt is in the closed position the bolt head is enclosed and supported within the lock ring and action body.
- The firing pin cannot protrude from the front of the bolt face unless the bolt lugs are engaged within the lock ring.
- Dangerous gas leakage from the rear of the action body is minimised by a tight fitting bolt and a shroud assembly that assists the deflection of hot gases away from the operator.
- 3-position safety lever.

## 1.2 FIRING PIN COCKING INDICATOR

It is possible to determine if the Accuracy International AT308 rifle is 'cocked' and therefore ready to fire by the position of the firing pin protruding through the rear of the shroud.

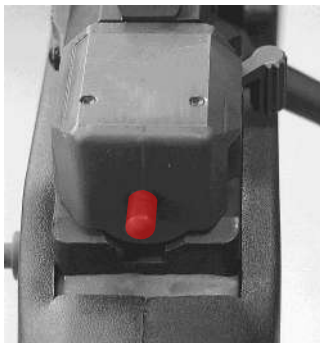

Firing Pin Cocking Indicator 'Cocked'

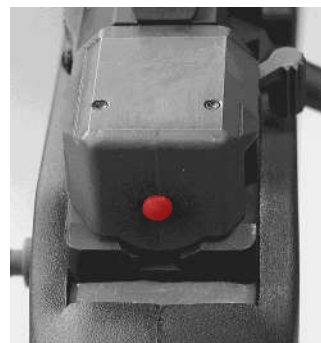

Firing Pin Cocking Indicator 'Fired'

Note: The firing pin has been highlighted in red for clarity.

### 1.3 SAFETY LEVER OPERATION

The Accuracy International AT308 rifle is fitted with a 3-position safety lever.

Note: The safety lever only operates when the rifle is 'cocked' and does not block the trigger in any of the three positions.

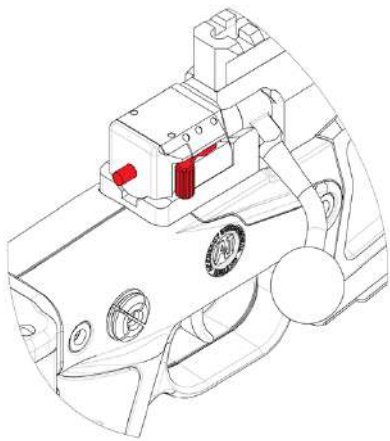

'Second Safe' Position

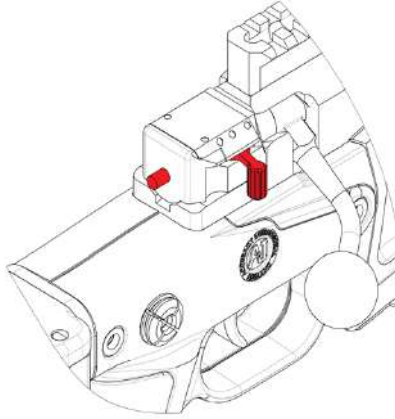

'First Safe' Position

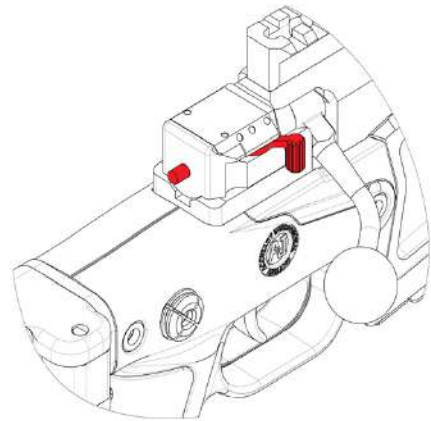

'Fire' Position

- |                               |   |   |
|-------------------------------|---|---|
| <b>'Second Safe' position</b> | - | Safety lever is in the rear position    |
| <b>'First Safe' position</b>  | - | Safety lever is in the centre position  |
| <b>'Fire' position</b>        | - | Safety lever is in the forward position |

#### **'Second Safe' position:**

- The firing pin is drawn back from the trigger mechanism and is physically blocked from moving forward.
- The bolt is locked in the closed position

#### **'First Safe' position:**

- To apply the 'first safe' position the lever must be brought back to the 'second safe' position then moved forward to the 'first safe' position.
- The firing pin is drawn back from the trigger mechanism and is physically blocked from moving forward.
- The bolt is unlocked and may be used to unload cartridges in a safe manner.

#### **'Fire' position:**

- The bolt is unlocked and can be manipulated.
- The firing pin is not blocked and the weapon can be fired.

## 1.4 SAFETY PRECAUTIONS

**WARNING** - Users and personnel responsible for the weapon must comply with the following SAFETY PRECAUTIONS. For the purposes of health and safety, all warnings and cautions must be adhered to.

Safety precautions should be carried out:

- On initial receipt of the weapon.
- Before use.
- After use.
- Before maintenance or cleaning procedures
- Before any inspection procedure.
- Before any non tactical movements.
- Prior to the weapon being placed in a transit case or drag bag.
- When the documentation recommends it.

### SAFETY PRECAUTIONS:

- Hold the weapon securely, do not place finger inside trigger guard.
- Point the weapon in a safe direction.
- Remove magazine (if fitted).
- Check that the safety is in the 'fire' position.
- Orientate the ejection port downwards and open the bolt and slide to rear.
  - Watch for a live cartridge or empty case ejecting
- Inspect the chamber and bolt face for a live cartridge or empty case.
  - Visual Check - Look through the ejection port.
  - Physical Check - Use a finger to check the chamber and bolt face.
- Remove any cartridge or case from the weapon.
- With the bolt left 'open', the rifle is now safe to handle.

Where possible, the bolt should be left 'open' to identify to others that it is safe. However, should the bolt be required in the 'closed' position:

- Pull and hold the trigger while closing the bolt.
- Fit an empty magazine, if required.
- The rifle is now safe to handle.



**WARNING - DANGER TO LIFE AND LIMB: IF THE BOLT IS NOT FULLY CLOSED WHEN THE RIFLE IS FIRED, THE COCKING PIECE COULD STRIKE THE BOLT CAUSING POSSIBLE MISFIRES.**

- The extractor does not engage the cartridge rim unless the bolt is fully closed.
- Failure to fully close the bolt every time it is manipulated may result in a live round being left in the chamber.
- Attempting to load a second round will result in a stoppage. This is known as "double feeding".

## 1.5 WARNINGS



**THE USE OF MISMATCHING 'FIRING TRAIN' PARTS AND ASSEMBLIES POSES A SERIOUS RISK TO LIFE AND LIMB. DO NOT FIRE THE RIFLE IF THE SERIAL NUMBERS OF THE ACTION BODY, BOLT AND BOLT / FIRING PIN ASSEMBLY DO NOT MATCH.**

### WEAPON STATUS.

When users are not aware of the weapon status, i.e. loaded, unloaded, cocked or fired, the user must assume the weapon is LOADED and carry out the SAFETY PRECAUTIONS set out in section 1.4.

### HANDING OVER WEAPONS.

A weapon which is to be handed over to another individual must be unloaded and presented with the bolt in the 'open' or rearwards position.

### TACTICAL MOVEMENTS.

Tactical movements with a loaded weapon are only to be performed with the safety lever on '2nd safe' position.



**WARNING - DANGER TO LIFE AND LIMB: THE TRIGGER UNITS FITTED INTO ACCURACY INTERNATIONAL RIFLES ARE DESIGNED AND FACTORY SET AS TWO-STAGE TRIGGERS. THEY MUST NOT BE ADJUSTED UNDER ANY CIRCUMSTANCES INTO A SINGLE STAGE TRIGGER. TRIGGER UNITS SHOULD ONLY BE ADJUSTED IN ACCORDANCE WITH 'APPROVED' ACCURACY INTERNATIONAL MAINTENANCE MANUALS.**

**FAILURE TO COMPLY WITH THIS WARNING COULD RESULT IN SERIOUS INJURY OR DEATH.**

## 1.6 SAFETY LEVER - FIELD SAFETY CHECK

The following procedure should be carried out before each time the rifle is used to ensure the safety lever is functioning correctly. This does not replace the need to have the safety mechanism routinely tested in accordance with the Accuracy International Maintenance Manual.

- Ensure the weapon is unloaded and safe to handle.
- With the bolt assembly fitted into the action body, open then close the bolt leaving it in the cocked position.
- Move the safety lever into the '1st safe' position. See section 1.3.
- Pull and release the trigger six times, remove your finger from the trigger.
- Push the safety lever forward into the 'FIRE' position.
- The firing pin should not be released, but still be retained by the safety mechanism.
- Pull the trigger to release the firing pin.
- Repeat this process two or three times to confirm that the system is safe.
- If the firing pin is released when the safety lever is moved to the fire position the rifle is deemed unsafe and must be returned to an Accuracy International trained armourer or gunsmith for maintenance in accordance with the Accuracy International maintenance manual.

## 1.7 CARTRIDGE HEADSPACE

Cartridge headspace defines the distance between the bolt face and the cartridge datum reference within the chamber when the bolt is closed, as shown in the image below. This is a critical safety feature on all rifles, regardless of manufacturer.

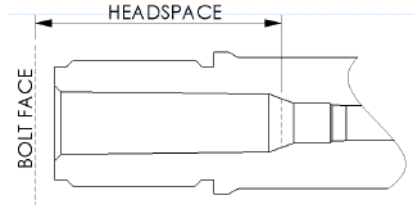

For the user's safety and to maximise cartridge compatibility, the headspace measurement on every Accuracy International rifle is inspected before leaving the factory.

However, during the working life of the rifle, wear to key components and new barrel fitting may increase the cartridge headspace. If this becomes excessive, it can lead to misfires, a loss of accuracy, and possible damage to the rifle due to a ruptured case.

It is therefore essential to check the cartridge headspace using Accuracy International specification gauges throughout the life of the rifle, particularly after a new barrel is fitted.



**EXCESSIVE HEADSPACE CAN BE HAZARDOUS AND MAY LEAD TO MISFIRES AND CARTRIDGE CASE RUPTURES**

### Instructions for checking the headspace dimension:

Headspace gauges are used to specify a maximum headspace for safety purposes using 'GO' and 'NO GO' gauges.

1. Ensure the chamber is clean before inserting the gauge into the chamber through the ejection port. Note: - To prevent damaging the chamber, ensure the gauge is fully inserted into the chamber before attempting to close the bolt.
2. Gently close the bolt handle down to a stop, without using excessive force.
3. If the bolt closes fully on the 'GO' gauge the headspace is acceptable.
4. If the bolt closes fully on the 'NO GO' gauge using a minimum amount of force, the headspace is out of tolerance and indicates that the rifle's accuracy and safety is compromised – the rifle must be inspected by a suitably qualified gunsmith/armourer before further use.

Accuracy International Approved Headspace Gauge Part Numbers:

**.308/7.62x51**

AITG-0010-A3 - Go Gauge  
AITG-0011-A3 - No-Go Gauge



## 2. PARTS IDENTIFICATION

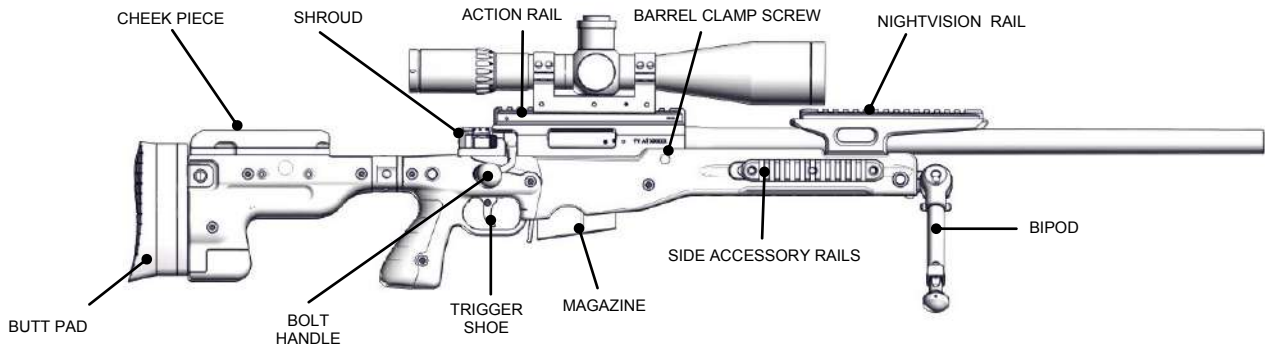

## 3. TECHNICAL SPECIFICATION

Calibre	:	.308 / 7.62x51mm
Action	:	Front Locking, 6 lugs.
Bolt	:	60 degrees opening, 6mm striker fall.
Trigger	:	2-stage, adjustable, set between 1.5 to 2 Kg (3.3lbs - 4.4lbs). Adjustable for reach.
Barrel	:	20" / 24" / 26" Stainless match-grade; 1 in 12" twist
Safety	:	3-position safety draws back and retains the firing pin, and depending on the safety position, either locks the bolt closed or allows it to be cycled in a 'safe' condition.
Stock	:	Optional folding stock, fitted with Adjustable Cheek Piece and Butt spacers. Optional height and angle quick adjust butt system.
Optic rail	:	20 MOA STANAG RAIL
Night Vision Mount	:	Optional co-planar mounting bracket allows the user to mount various types of inline night vision and thermal sighting equipment.
Magazine	:	10 shot, double-stack, detachable, box-type magazine.
Accessory Rails	:	Optional kit available to mount side accessory rails.
Sling Points	:	'Flush Cup' sling points fitted.
Length	:	1170mm - (excl. spacers), 965mm - with butt folded.
Weight	:	6.3kg (13.9lbs) (unloaded magazine) *This excludes the bipod, scope sight and additional accessory rails.
Butt Spacer Kit	:	1 x 20mm and 1 x 10mm Spacers
Usage	:	Designed for all uses up to and including military use in extreme environmental conditions.

## **4. SETTING UP THE RIFLE**

Prior to firing, the rifle should be setup to suit the user. The rifle is customisable for length of pull and cheek piece height.

To set up the rifle:

- Adopt the prone firing position.
- Adjust the bipod legs to suit terrain.
- Fully open the bolt.
- Adjust cheek piece to achieve a comfortable position and correct eye alignment with sight.
- If necessary, adjust the butt length (and height, if height adjustable butt option is fitted).
- Check and, if necessary, adjust the position of the telescopic sight to obtain correct eye relief as detailed in section 4.9.

## 4.1 BIPOD FITTING AND OPERATION (ACCURACY INTERNATIONAL MODEL)

To remove the bipod:

- Operate the bipod release catch.
- Pull the bipod forward out of its mounting.

To fit the bipod:

- Offer the bipod spigot up to the mounting.
- Push the bipod into the mounting until the release catch engages.

To deploy and adjust the legs:

- Rotate each leg round through 90 degrees until the leg locking button engages.
- Depress the leg catch to deploy the inner leg, while supporting the weight of the rifle.
- Alternatively the leg can be pulled down to find the desired height once the first locking position has been disengaged.

To adjust the bipod tilt or 'Cant' tension:

- The tension/resistance against the 'cant' or 'loll' can be tightened or loosened by using the tension adjustment knob.

To collapse the bipod:

- Depress the leg catch and push the inner leg(s) fully in.
- Depress the leg locking button and rotate the leg forwards or rearwards until the detent pin engages.

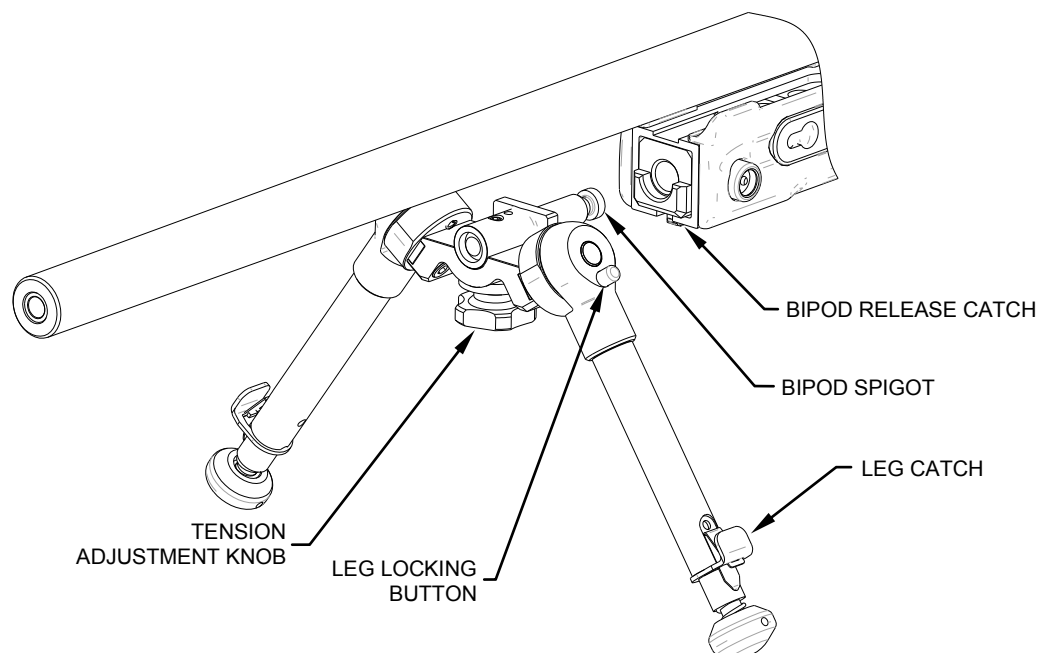

## 4.2 BIPOD REMOVAL AND REFITTING (HARRIS BIPOD).

- To remove the bipod, loosen the retaining screw, pinch the locating tabs together and remove the bipod.
- To fit the bipod, offer the locating tabs to the bipod adaptor stud. Once properly located the bipod can be secured by tightening the retaining screw.
- The Harris bipod adaptor can be moved along the forend in the same way as the accessory rails (see section 4.5), prior to fitting the bipod.

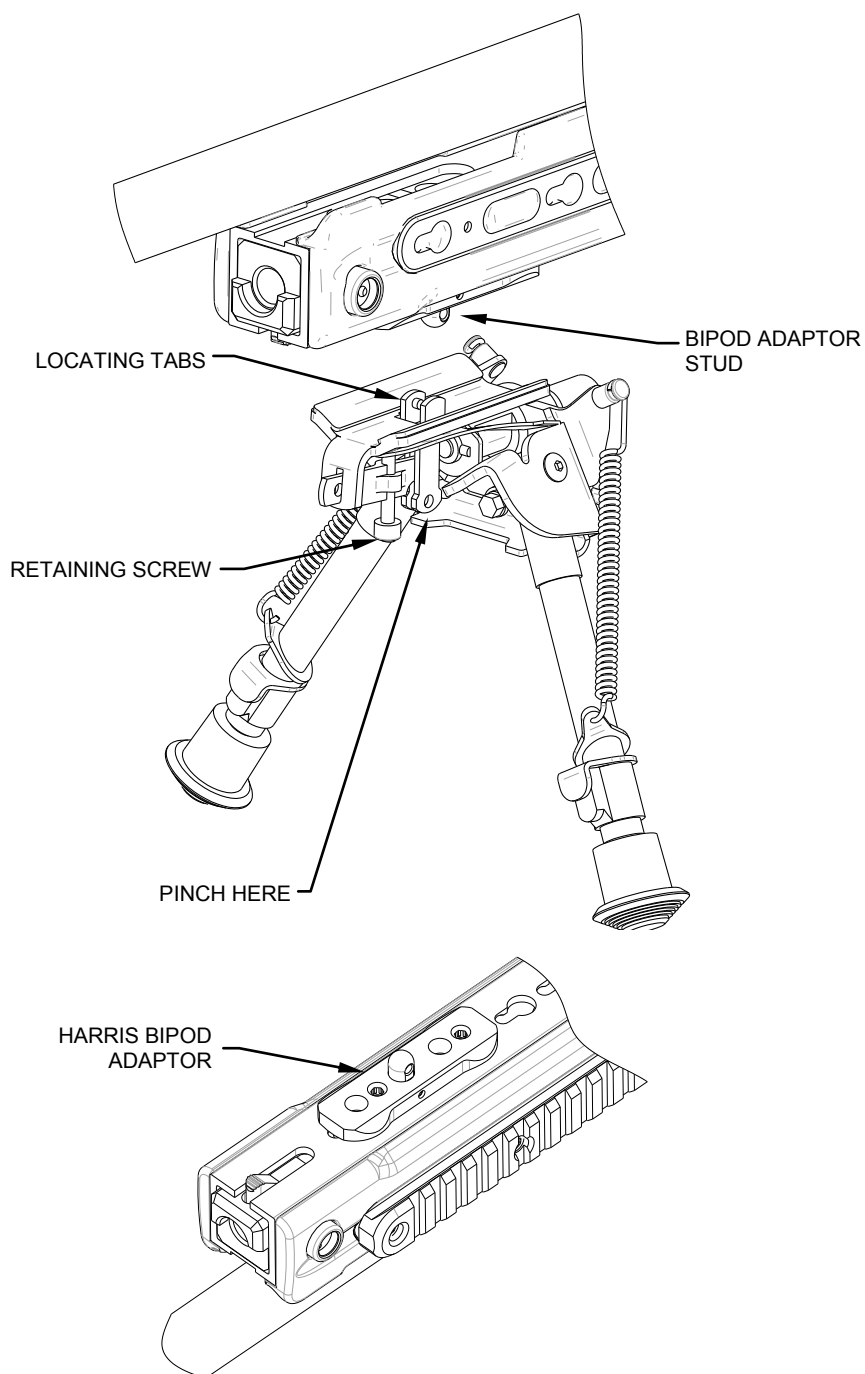

## 4.3 CHEEK PIECE ADJUSTMENTS

The AT308 rifle is fitted with a cheek piece that can be adjusted for height and lateral position.

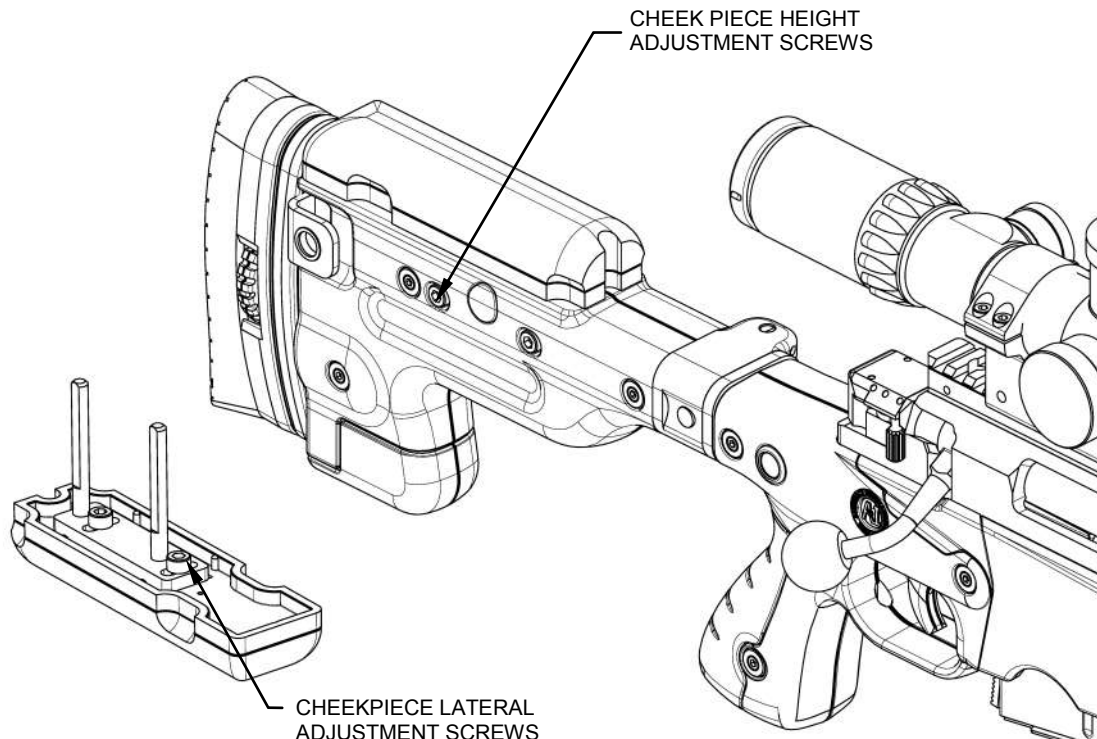

To adjust the height of the cheek piece, or to remove the cheekpiece:

- Loosen the cheek piece adjustment screws
- Adjust the height of the cheek piece to the desired position, or remove as required.
- Tighten the cheek piece adjustment screws.

To adjust the lateral position of the cheek piece (left and right):

- Loosen the vertical adjustment screws and remove the cheekpiece / platform assembly from the butt sub-frame.
- Loosen the screws holding the cheekpiece on platform, adjust and retighten the screws.
- Replace cheekpiece platform assembly in the butt sub-frame, adjust the cheekpiece height as desired and retighten screws.

## 4.4 BUTT PAD ADJUSTMENTS

The AT308 length of pull can be extended by fitting butt spacers from the supplied kit. One 10mm and 20mm spacer is supplied with the rifle along with appropriate length screws to suit the desired combination.

Fitting :

- If fitted, loosen the height adjustable butt, rotate through 90° to reveal the butt pad securing screws and re-tighten.
- Using the supplied 4mm hex key, loosen and remove the two butt pad screws.
- Select the appropriate combination of butt spacers necessary to provide the desired length of pull.
- Select the correct length screws to suit the number of spacers being used (see guide below).
- Fit the butt pad and spacer/s as shown below.
- Using the supplied 4mm hex key, tighten the two butt pad screws. These should be tightened to 3.5Nm if a torque screwdriver/wrench is available.

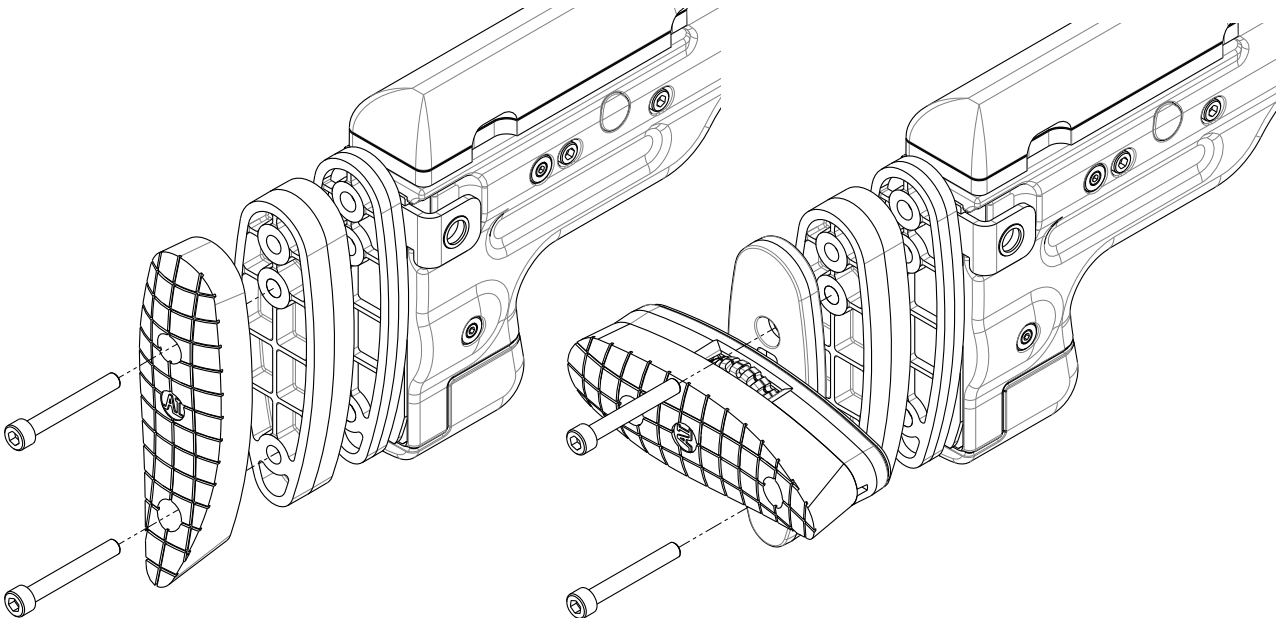

STANDARD BUTT ASSEMBLY

OPTIONAL HEIGHT ADJUSTABLE BUTT ASSEMBLY

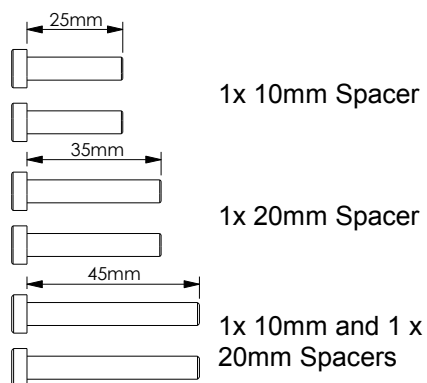

Screw Selection Guide

## 4.5 FITTING AND REMOVING ACCESSORY RAILS AND MOUNTS

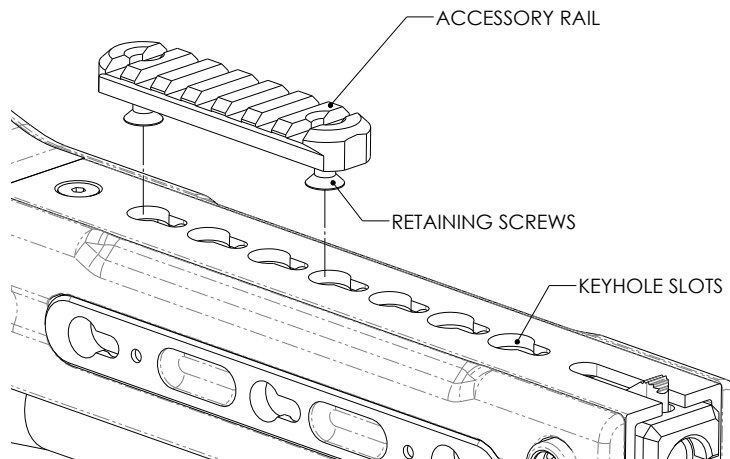

### Removing an accessory rail / bipod mount:

- Using a 4mm hex key, loosen the retaining screws until light resistance is felt, then stop - do not continue to loosen.
- Slide the rail to the rear of the key hole slots (open end).
- Lift the rail clear of the chassis.

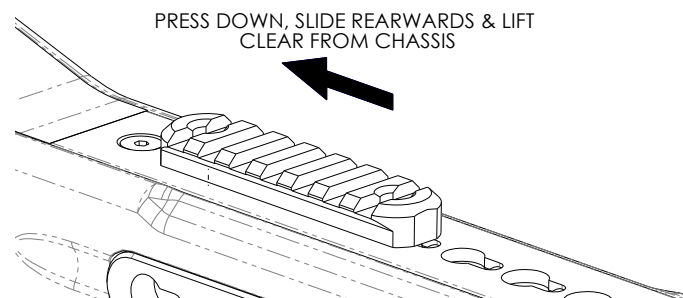

### Refitting the accessory rail:

- With the retaining screws in the extended position shown below, position the screw heads over the open end of the desired keyhole slots.

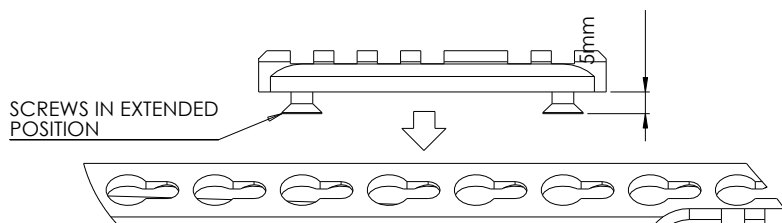

- Place the heads of the screws through the open end of the keyhole slots.
- Slide the rail forward until it comes to a stop at the closed end of the keyhole slots.
- Pull the rail upwards & tighten the retaining screws, this will draw the rail to the surface of the chassis.
- Check the rail does not move and is flat against the chassis.

## 4.6 NIGHT SIGHT BRACKET FITTING AND REMOVAL:

### To fit the bracket:

Depending on the barrel configuration it may be necessary to either remove the barrel (see section 10) or muzzle brake (see section 4.7) prior to fitting the Night Sight Bracket. The following procedure assumes the barrel is fitted.

- Slide the bracket down the barrel towards the mounting slot, observing the correct orientation of the bracket.
- Align the night vision bracket with its mounting slot
- Pass the two M6 mounting screws through the open diameter of the two keyhole slots closest to the end of the rifle and tighten to a torque of 3Nm.
- Refit the muzzle brake, if required.

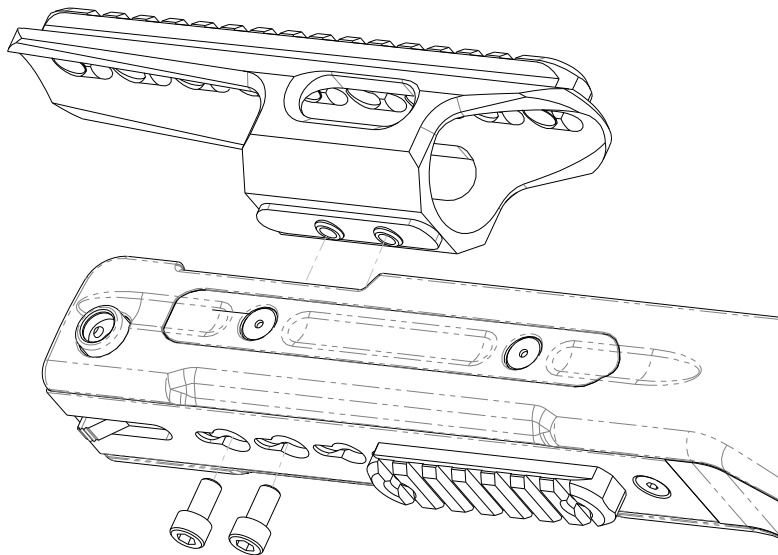

### To remove the bracket:

- Remove the muzzle brake, if fitted.
- Loosen and remove the two M6 mounting screws.
- Ease the Night Sight Bracket out of its mounting slot and carefully slide over the barrel.
- Refit the muzzle brake, if required.



## 4.7 REMOVING AND REFITTING THE MUZZLE BRAKE (A.I. MODEL)

### Muzzle brake removal

- Where fitted, unscrew and remove the left-hand threaded muzzle brake thread protector.  
Note: If the thread protector is difficult to unscrew by hand, insert a 3 mm hexagon key through the hole in the side of the thread protector for additional leverage.
- Use a 4 mm hexagon key to slacken the muzzle brake retaining screw.
- Unscrew the muzzle brake from the barrel (anti-clockwise).
- If tight, remove the retaining screw and place a coin or similar into the slot: refit the retaining screw on the opposite side from which it was removed. Carefully tighten the screw onto the coin to slightly open the muzzle brake slot, taking care not to overstress the components.
- A suitably sized spanner may be used across the two flats on the muzzle brake boss. Take care not to damage the foresight location faces whilst unscrewing the muzzle brake.

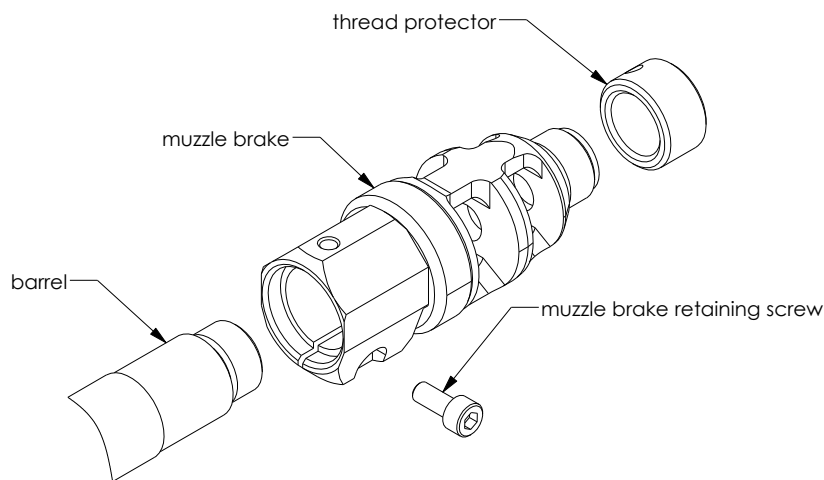

### Muzzle Brake Refitting

- To refit the muzzle brake, ensure both threads are clean and free from damage.
- Lightly lubricate the thread and its location diameter with XG 279 grease or similar.
- Screw the muzzle brake onto the barrel in a clockwise direction until it stops.
- Unscrew the muzzle brake until the crown is flush or slightly under flush with the muzzle port and is correctly aligned with the action as shown below.
- Refit the retaining screw, if it has been removed, using a 4mm hexagon key and tighten to 4.0 Nm (36in/lbs).

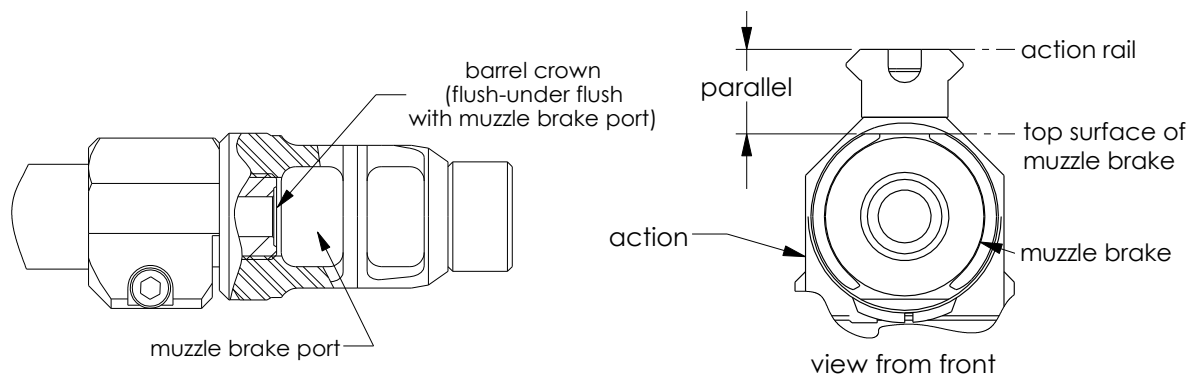

## 4.8 FITTING AND REMOVING RAIL MOUNTING PLATES

- Remove the two M3 stock side screws as shown below:

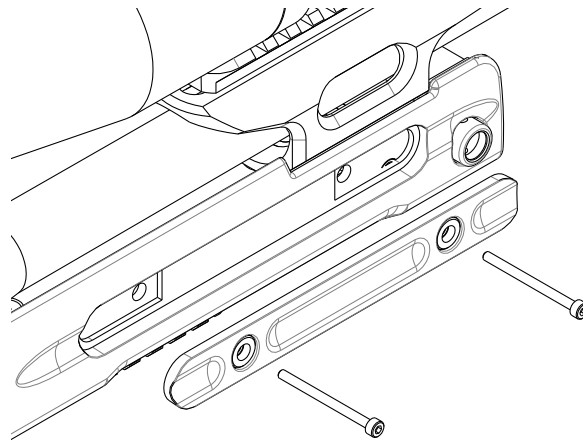

- Remove the left and right, blanking panels
- Locate the two rail mounting plates as shown below, observing the correct orientation.  
**Note: Both the rail mounting plates and the stockside blanking panels must be correctly positioned and orientated to fit properly.**

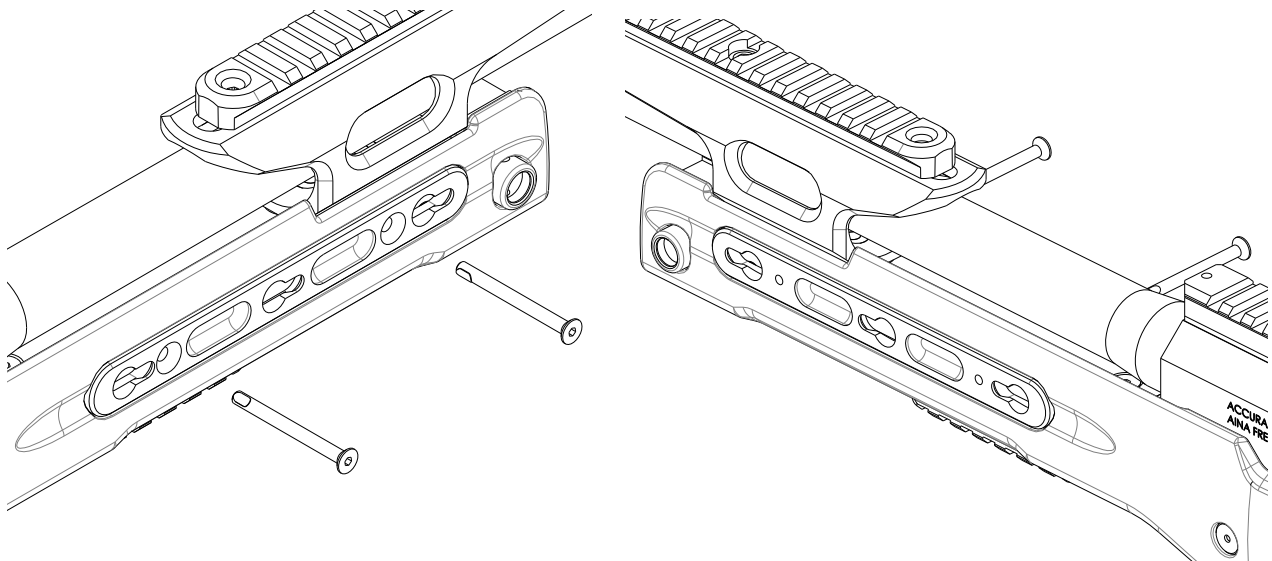

- The rail mounting plate retaining screws are pre-coated with Loctite to help prevent the screws working loose.
- The mounting plate screws should be tightened to a torque of 2.5Nm.
- Additional accessory rails may now be added or removed as detailed in section 4.5.

## 4.9 SCOPE MOUNT ADJUSTMENT

It is possible to adjust the position of the scope mount on the action rail for eye relief.

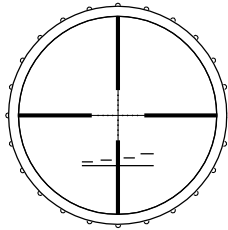

(1 - Correct eye relief)

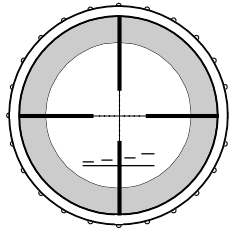

(2 - Short eye relief)

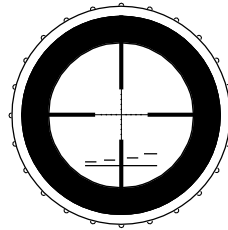

(3 - Long eye relief)

If the distance between the eye and the eyepiece is too short, then a shadow will appear at the extreme edges of the reticle, as shown in the diagram below (image 2) and the field of view will be narrower.

If the distance between the eye and the eyepiece is too long, then the extreme edges of the reticle are not visible, (image 3) and the field of view will be narrower.

If the distance between the eye and the eyepiece is correct, then the whole of the reticle and the full field of view will be visible, (image 1).

### To reposition the scope mount:

- Use the 4mm hex key to loosen the three scope mount screws.
- Once loose, it should be possible to roll the scope mount off the action rail.
- Choose the new desired location and roll the scope mount onto the rail ensuring that the recoil lug is located in one of the slots on the rail.
- Push forward on the scope to ensure the recoil lug is in contact with the front face of the rail slot.
- Tighten the three screws using the 4mm hex key.

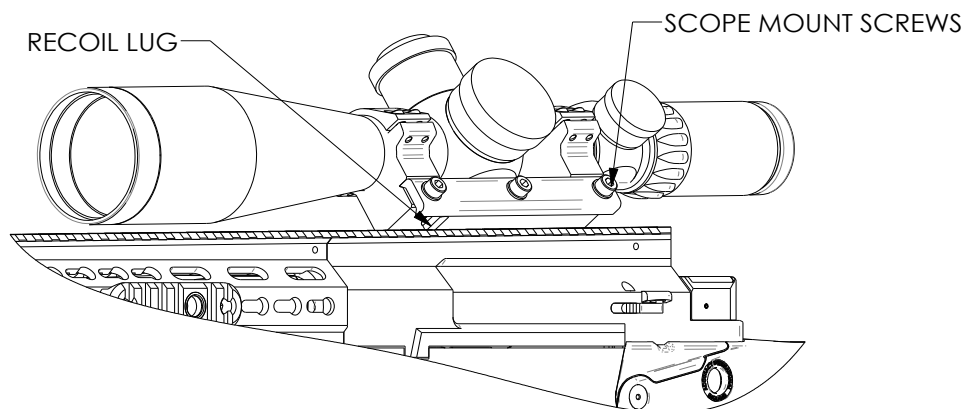

### Notes:

- It is recommended that the scope is re-zeroed following any changes to its position. Unnecessary removal and refitting of the scope mount should therefore be avoided, where possible.
- Correct eye relief may also be obtained by adjusting length of pull.
- The cheek piece should be adjusted to achieve the correct alignment between the eye and eyepiece.

## 5. FOLDING THE STOCK

The AT308 rifle may be supplied with an optional folding stock to reduce overall length for transportation.

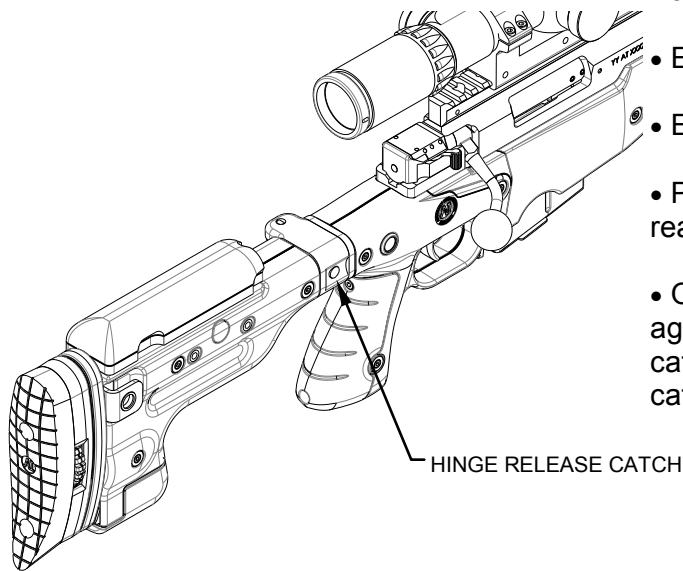

### To fold the stock:

- Ensure the rifle is safe to handle.
- Ensure the bolt is fully closed.
- Press the hinge release catch and fold the rear frame.
- Once folded, push the rear frame firmly against the pistol grip ensuring that the male catch has engaged with the female retaining catch.

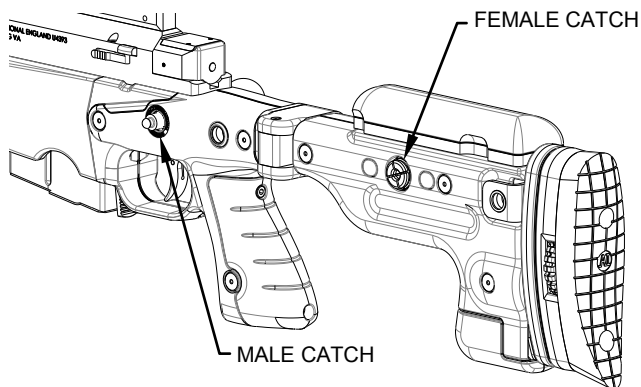

### To unfold the stock:

- Pull the rear frame away from the chassis and rotate to a positive stop.
- Ensure that the rear frame release catch has engaged.

## 6. FIELD STRIPPING THE RIFLE

Before stripping the rifle, carry out the safety precautions as described in section 1.4.

### To field strip the rifle:

- Depress the magazine catch and remove the magazine (if fitted).
- Cover the lenses of the telescopic sight.
- Remove the sling (if fitted)
- FOLDING CHASSIS MODEL: Partially fold the rear frame to allow the bolt to be removed as shown below.
- FIXED CHASSIS MODEL: Loosen the cheek piece retaining screws and remove the cheek piece as described in section 4.3.
- Open the bolt fully.
- Press and hold the bolt release catch and slide the bolt rearwards to remove.

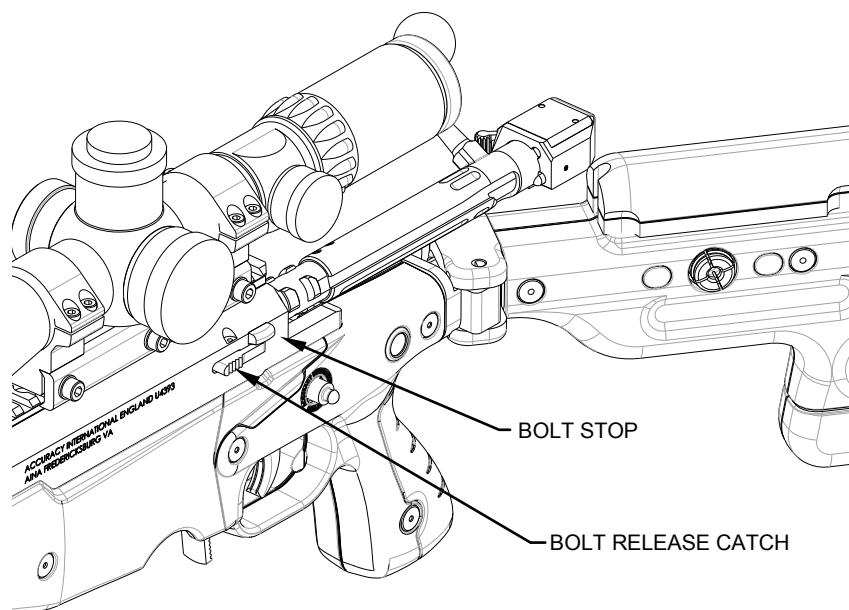

### To reassemble after field stripping:

- Ensure the serial numbers on the Action Body, Bolts and Shroud match, if not, report the issue to the appropriate authority.
- FOLDING CHASSIS MODEL ONLY: Fold the rear frame through 45 degrees, as shown above.
- With the bolt assembly in the 'cocked' position (see section 6.1 - image 3), align the bolt assembly with the action body as shown above.
- Press and hold the bolt release catch.
- Slide the bolt assembly half way into the action body and release the bolt release catch.
- Attempt to rotate the bolt slightly left and right until the bolt engages with the bolt stop.
- Cycle the bolt fully several times to ensure correct fitment & operation.
- Unfold the rear frame fully or refit the cheek piece assembly depending on chassis type.
- Refit the sling.
- Refit an empty magazine.

## 6.1 STRIPPING THE BOLT ASSEMBLY

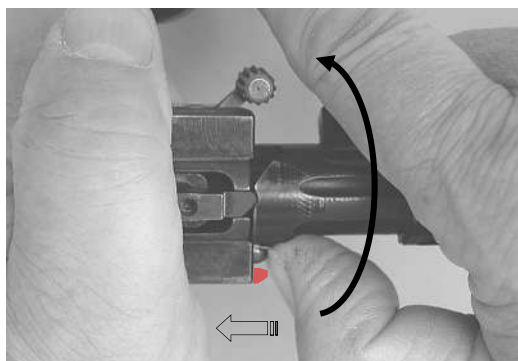

### To strip the bolt assembly:

- Remove the bolt as per the field stripping instructions.
- Grasp the bolt and the shroud as shown above.
- Depress the pin bolt location with a thumb as shown above and turn the bolt clockwise until the shroud and the firing pin assembly can be withdrawn from the bolt body.
- Remove the firing pin and the shroud assembly from the bolt.
- The firing pin assembly is adjusted to suit the bolt supplied with this rifle and must not therefore be used with another rifle.

### To reassemble the bolt assembly.

- Carefully guide the Shroud and Firing Pin assembly into the Bolt body ensuring that the retaining lugs on the shroud body line up with the opening in the bolt body. See image 1 below.
- Push and hold the Shroud into the Bolt Body to compress the firing pin spring. See image 2 below.
- Rotate the shroud body clockwise until the cocking piece drops into the detent in the bolt body as shown in image 3 below.



Image 1



Image 2

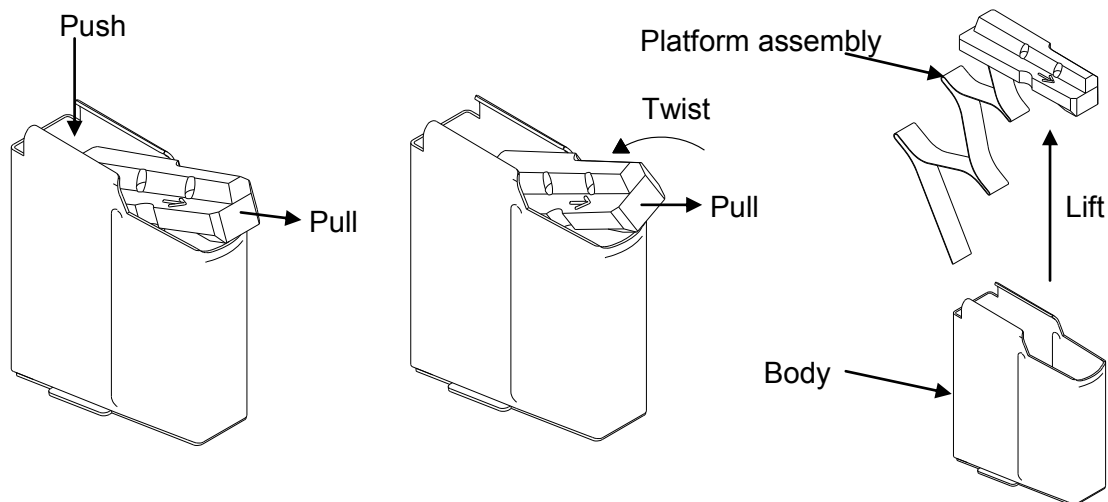

Image 3

## 6.2 MAGAZINE STRIPPING AND REASSEMBLY

### STRIPPING:

- Press down and push forward on the rear of the magazine platform.
- Hold the front of the magazine platform/spring assembly with the other hand and twist the platform clockwise through approximately 45 degrees as illustrated below.
- Keeping the magazine platform/spring assembly twisted, pull the platform forward until it clears the magazine lips.
- Remove the magazine platform/spring assembly from the magazine body.
- The magazine spring is riveted to the platform and it is not recommended that they are separated for any maintenance activities.



### REASSEMBLY

- Hold the front of the platform and insert the assembly into the magazine body ensuring that the bottom fold of the spring lays flat on the bottom of the magazine.
- Twist the platform clockwise by approximately 45 degrees and slide the platform rearwards into the magazine body.
- Press the platform fully into the magazine body and release several times to ensure that the platform spring/assembly moves correctly and freely.

## 7. PREPARING AND FIRING THE RIFLE

### 7.1 MAGAZINE LOADING

The AT308 rifle is supplied with a 10 round, double stack, detachable magazine.

#### To load a magazine:

- Offer the first round onto the top of the empty magazine.
- Push the round down until it is caught by the magazine feed lips and platform.
- Push the round fully rearwards.
- Repeat for the next round, again pushing it fully rearwards.
- Load a total of 10 rounds.



### 7.2 LOADING THE RIFLE

#### To load rifle:

- Point the rifle in a safe direction.
- Where possible, open the bolt by raising the bolt lever and pulling the bolt fully rearwards.
- Offer the top of the loaded magazine to the opening of the magazine aperture and slide upwards until the magazine catch engages on the back of the magazine.
- Pull firmly downwards on the magazine to ensure it is securely retained.
- Unless already open, open the bolt by raising the bolt lever and pulling the bolt fully rearwards.
- Feed a round from the magazine into the chamber, by sliding the bolt fully forward and by closing the bolt lever fully.
- The cocking indicator will protrude prominently from the rear of the shroud (see section 1.2).

#### **THE RIFLE IS NOW COCKED AND READY TO FIRE**

- Apply the safety lever, if necessary, as described in section 1.3.



**WARNING: ALWAYS CLOSE THE BOLT FULLY. FAILURE TO FULLY CLOSE THE BOLT EACH TIME IT IS MANIPULATED COULD RESULT IN A LIVE ROUND BEING LEFT IN THE CHAMBER.**

#### NOTES:

- The extractor does not engage on the cartridge rim unless the bolt is fully closed.
- When the magazine is full, the magazine catch is more difficult to engage with the bolt closed. The first round will also be more difficult to feed into the chamber than subsequent rounds.



## 7.3 FIRING AND OPERATING THE RIFLE

The following sequence will be of assistance when firing and operating the rifle:

- Adjust the telescopic sight eyepiece to bring the reticule into sharp focus and adjust the parallax drum (where fitted) to suit the distance.
- Set the elevation and windage on the telescopic sight.
- Get into a comfortable and stable fire position.
- Set the safety lever to 'FIRE' position.
- Ensure correct aim, take up first stage and pull the trigger.
- Follow through and observe the target.
- Remain "on aim" during recycling of bolt.

**NOTE:** The following procedure minimises rifle and body movement during the firing sequence (right handed operators only).

- To open the bolt, place the thumb of the right hand on top of the shroud body and grasp the bolt with the fingers of same hand.
- Bring the fingers towards the thumb. If any resistance is felt during initial unseating of the fired case (primary extraction) increase upward pressure on the bolt handle with the fingers.
- Pull the bolt FULLY rearwards to allow ejection of the fired case and pickup of next round.
- Push the bolt firmly forward to feed next round into the chamber. Close the bolt handle fully.
- Repeat sequence for each round as required.

## 7.4 RELOADING THE RIFLE

**To reload the rifle:**

- Remove the empty magazine by depressing the release catch and pulling down on the magazine.
- Pull the bolt FULLY rearwards before re-closing the bolt fully to chamber a new cartridge.
- Apply the safety lever, when necessary.
- The rifle is now reloaded and ready to continue firing.

## 7.5 UNLOADING THE RIFLE

Note the position of the Firing Pin Cocking Indicator (see section 1.2). If fired, use drill 1, If cocked, use drill 2.

### **Drill 1: Unloading rifle after firing (Firing Pin Cocking Indicator shows 'fired')**

- Point the weapon in a safe direction.
- Hold the weapon securely, do not place finger inside trigger guard.
- Remove magazine (if fitted).
- Open the bolt and fully slide to rear, ejecting the fired case.
- Inspect the chamber to ensure it is empty
  - Visual Check - Look through the ejection port.
  - Physical Check - Use a finger to check the chamber and bolt face.
- Remove any cartridge or case from the weapon.
- With the bolt left 'open', the rifle is now safe to handle.

Where possible, the bolt should be left 'open' to identify to others that it is safe. However, should the bolt be required in the 'closed' position:

- Pull and hold the trigger while closing the bolt.
- Fit an EMPTY magazine, if required - the rifle is now safe to handle.

### **Drill 2: Unloading a live cartridge (firing pin cocking indicator shows 'cocked')**

- Point the weapon in a safe direction.
- Hold the weapon securely, do not place finger inside trigger guard.
- Apply the safety lever to '1<sup>st</sup> SAFE' position (see section 1.3).
- Remove the magazine.
- Slowly cycle the bolt to unload the live cartridge from the chamber.
- Carefully remove the live round by hand.
- Inspect the chamber to ensure it is empty
  - Visual Check - Look through the ejection port.
  - Physical Check - Use a finger to check the chamber and bolt face.
- Remove any remaining cartridges from the weapon.
- With the bolt left 'open', the rifle is now safe to handle.

Where possible, the bolt should be left 'open' to identify to others that it is safe. However, should the bolt be required in the 'closed' position:

- Cycle the bolt to the closed position
- Push the safety lever into the 'Fire' position.
- Cycle the bolt into the 'open' position.
- Pull and hold the trigger while closing the bolt.
- Fit an EMPTY magazine, if required.
- The rifle is now safe to handle.

## 7.6 FITTING AND REMOVAL OF THE TACTICAL SUPPRESSOR

A suppressor can be fitted to rifles with a tactical (threaded) muzzle brake.

### To fit the suppressor:

- Unload the rifle and carry out safety precautions (see section 1.4).
- Inspect the inside of the suppressor to ensure it is clear before firing.
- Ensure the suppressor cover is correctly and securely fitted, if supplied.
- Locate the suppressor onto the muzzle brake
- Screw the suppressor anti-clockwise onto the barrel (it has a left hand thread)
- Ensure that the suppressor has locked up on the muzzle brake and is securely fitted.



**CAUTION**

**THE SUPPRESSOR'S OUTER CASE CAN GET VERY HOT DURING USE.**

**IF REMOVING THE SUPPRESSOR STRAIGHT AFTER USE, ENSURE THE NECESSARY PRECAUTIONS ARE TAKEN TO PREVENT INJURY.**



**CAUTION**

**THE THREAD ON THE FRONT OF THE MUZZLE BRAKE IS A LEFT-HAND THREAD. PLEASE TIGHTEN AND LOOSEN THE THREAD PROTECTOR OR SUPPRESSOR ACCORDINGLY.**



**CAUTION**

**THE SUPPRESSOR MUST BE REMOVED AND ITS LOCATION DIAMETER AND 'O'RING CLEANED EVERY TIME THE BARREL IS CLEANED (SEE SECTION 11.10).**

### To remove the suppressor:

- Unload the rifle and carry out safety precautions.
- Allow the suppressor to cool, or use a thermal barrier.
- Unscrew the suppressor from the muzzle brake by hand turning it clockwise (it has a left hand thread).



**CAUTION**

**THE INTERNAL COMPONENTS ARE SEALED WITHIN THE SUPPRESSOR HOUSING. NO USER REPLACEMENT PARTS ARE WITHIN THE SUPPRESSOR HOUSING. DO NOT ATTEMPT TO DISMANTLE THE SUPPRESSOR.**

## 8. STOPPAGE AND TROUBLESHOOTING DRILLS

If the rifle, magazines and ammunition are kept clean and maintained correctly, few stoppages should occur. However, if the rifle does fail to fire or operate as expected, the following drills must be carried out.



**FAILURE TO FIRE: IF THE RIFLE FAILS TO FIRE, MAINTAIN AIM IN A SAFE DIRECTION FOR AT LEAST 30 SECONDS BEFORE ATTEMPTING TO OPEN THE BOLT. THE CARTRIDGE'S PRIMER MAY BE BURNING SLOWLY AND MAY CAUSE WEAPON TO FIRE UNEXPECTEDLY. FAILURE TO FIRE CAN BE CAUSED BY A SLOW BURNING PRIMER, A LIGHT STRIKE FROM THE FIRING PIN OR A ROUND NOT BEING LOADED INTO THE CHAMBER**

**IN ANY CIRCUMSTANCES, CARE MUST BE TAKEN WHEN THE BOLT IS OPENED - A FAULTY ROUND MAY STILL FIRE.**

### **Master Stoppage Drill**

The Master Stoppage drill should be carried out to determine the nature of the stoppage.

- Follow the 30 second rule above.
- Open the bolt and slowly pull it to the rear; a live round may be ejected.
- Inspect inside the action body and chamber as the next action will depend on what has been seen inside the action body.

### **Rounds in the Magazine**

If there are rounds in the magazine but no round in the chamber, the magazine could be incorrectly fitted or the bolt may not have been cycled correctly.

- Check that the magazine is correctly fitted, if necessary remove and refit.
- Pull the bolt fully rearwards, then push forwards and close.
- Continue firing.

### **No rounds in the magazine**

- Remove the empty magazine.
- Fit a loaded magazine onto the rifle.
- Pull the bolt fully rearwards then push forwards and close.
- Continue firing.

### **Obstruction in the action body—failure to eject**

If there is a live round or empty case present, this must be removed.

- Remove the magazine.
- Carefully remove the obstruction.
- Do not reload the removed live round until it has been inspected and deemed safe.
- Check the chamber is clear.
- Refit the magazine.
- Pull the bolt fully rearwards then push forwards and close.
- Continue firing.

The operator should check for component damage or obstructions that may impede the ejection of the weapon. Consistent failures to eject should be investigated by an Accuracy International qualified gunsmith or armourer.

## 8. STOPPAGE AND TROUBLESHOOTING DRILLS (CONTINUED)

### Obstruction in the chamber—failure to extract

If a live round or empty case is present in the chamber, this must be removed.

- Remove the magazine.
- Close the bolt fully.
- Set the safety to the '1st safe' position.
- Open the bolt to clear the obstruction.
- Check chamber is clear.
- Refit the magazine.
- Pull the bolt fully rearwards, then push forwards and close.
- Set the safety to the 'Fire' position.
- Continue firing.

Should the above drill not clear the obstruction, check the bolt and extractor for damage. Consistent failures to extract should be investigated by an Accuracy International qualified gunsmith or armourer. A cleaning rod may be used to remove an EMPTY case only by carefully inserting it into the bore from the muzzle end of the barrel.



**ENSURE THE CLEANING ROD IS REMOVED FROM THE BARREL BEFORE CONTINUING TO FIRE.**

### Slow burning primer/hang fire

If the round does not fire after 30 seconds, eject the round and inspect it. If the primer strike looks positive, the round must not be used and be disposed of safely. Persistent problems must be investigated and the ammunition batch should not be used until examined further.

### Light Strike

This can indicate that the bolt was not fully closed. Ensure that the bolt is closed fully each time a cartridge is chambered. The bolt may also require cleaning and light lubrication. If the problem continues, stop using the rifle and have it examined by an Accuracy International qualified gunsmith or armourer.

### 'Pierced' or 'Blanked' Primer

Should the ejected empty case have a 'pierced' or 'blanked' primer, the user should inspect the firing pin tip for damage. If the firing pin is damaged or if the problem persists, have the rifle examined by an Accuracy International qualified gunsmith or armourer.

### Hard Extraction

Hard extractions can be caused by a number of factors. A heavily 'fouled' barrel and chamber is a common cause. The rifle should therefore be cleaned regularly, as set out in the maintenance section of this manual. The user should also inspect the bolt head and extractor for cleanliness and or damage. Prolonged 'rapid' firing may also cause hard extractions. If this is the case, allowing the rifle to cool more frequently, if practical, may ease the problem.

Any other problems must be investigated by an Accuracy International qualified gunsmith or armourer.

## 9. TELESCOPIC SIGHT ADJUSTMENTS

The AT308 Sniper Rifle can be used with any telescopic sight that is fitted to a mount or scope rings suitable for use with a STANAG / MIL-STD 1913 rail. The operation of the sight can vary between manufacturers, but are similar in operation. These notes are based on the use of a Schmidt and Bender PM II 5-25x56 (0.1mrad) telescopic sight.

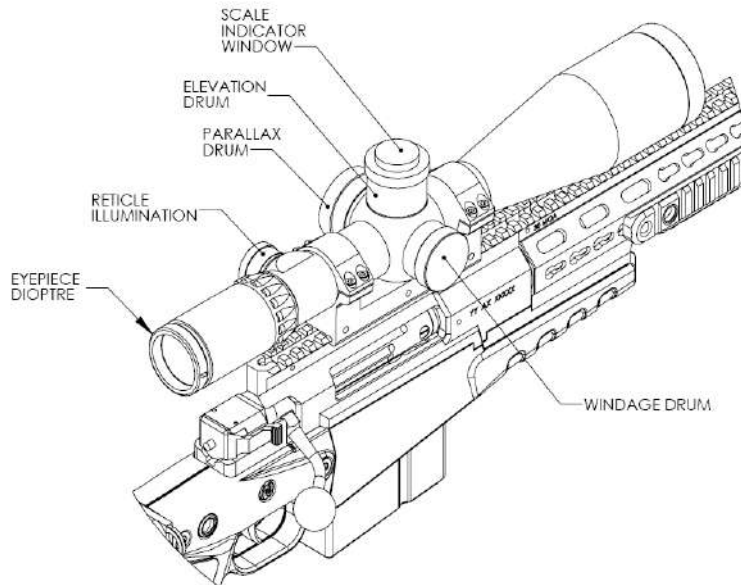

Elevation Drum shooting at

- This drum is used to apply vertical aiming corrections necessary for different distances and firing angles.
- The 5-25 x 56 scope is fitted with a double turn turret.
- When using the lower scale (0-14mrad) , the scale indicator is black.
- When using the upper scale (14-26mrad), the scale indicator is yellow.

Windage Drum

- This drum is used to make horizontal aiming corrections necessary to compensate for varying wind conditions. The drum scale is graduated from 0 to 6 MRAD to the left and from 0 to 6 MRAD to the right.

Parallax Drum

- The parallax adjustment allows the firer to correct any parallax error between the scope and the eye. It can also be used for basic range finding. The adjustment on the parallax varies on the scope model.

Reticle Illumination

- The Reticle illumination brightness is adjustable. It is powered by a single CR2032 (3v) battery, providing a minimum of 100 hours life. Illumination is switched off automatically after six hours to conserve battery life.

Magnification Ring

- This ring adjusts the image magnification on the scope. Accuracy International generally specify sights with reticles in the 1st focal plane to ensure the graduations remain the same size relative the target throughout the magnification range. This is particularly useful for consistent range estimation.

Eyepiece Dioptre

- The eyepiece adjustment allows the firer to achieve a sharp focus with the sight. To adjust the image focus, set the scope to the highest magnification then rotate the eyepiece counter-clockwise to its stop. Rotate the eyepiece clockwise until you see a sharp image of the reticle.

## 9.1 ZEROING THE TELESCOPIC SIGHT

The following procedure is provided as an example only. The same process can be used on short distance zeroing ranges as well as at 100m+. Always refer to the your sight manufacturer's instructions to ensure adjustments are carried out correctly.



**SHOOTING AT ANY DISTANCE WITH AN INCORRECTLY ADJUSTED SIGHT MAY RESULT IN DAMAGE TO PROPERTY, INJURY OR DEATH.**

- Before zeroing the rifle at an extended distance (100m+), the sight must be initially adjusted to ensure the point of impact will fall within a safe area of the range backstop / stop butt at the longer distance. This can be achieved by using a bore sighting device or by carrying out the procedure described below on a purpose built 25m zeroing range (or similar) using an appropriate zeroing target. Once these adjustments have been made, set the elevation and windage drums to zero, again using the method described below.
- Once satisfied that the point of impact is predictable enough to fire safely at greater distances, choose a suitably short range of a known distance to reduce the wind effects to a minimum, ideally 100m or 200m. Get into a comfortable and stable shooting position. With the rifle resting in this position, adjust the bipod to get the rifle at the correct height to point naturally at the target.
- Check the sights are reading zero on the windage and elevation sight knobs.
- Insert a loaded magazine, close the bolt, place the aiming point of the reticle on the aiming mark of the target and fire one shot. If this shot falls within the target area, fire two more shots. If the initial shot falls outside the target area, sandbag or hold the rifle carefully on the original point of aim and gently rotate the windage drum, without moving the rifle, until the reticle is vertically in line with the shot hole. Using the elevation drum, move the reticle up or down until it is positioned over the shot hole (See the Notes section below)
- Aim at the original aiming mark and ideally fire three more shots to form a small group.
- Again, sandbag or hold the rifle carefully on the original point of aim and use the sight knobs to finely adjust the reticle to the centre of the group.
- Fire a five shot group and make any final adjustments.
- Whilst holding the drums, firmly between the fingers loosen the grub screws (2 ea. per drum) using a suitable Hex (Allen) key.
- Rotate the Elevation and Windage drums to zero. Re-tighten the lock screws. The rifle is now zeroed at that range.
- Ballistic data can now be collected for each ammunition type at set distances. These records will enable the correct elevation setting to be quickly recalled at a later date.

### NOTES

If the shot is low, rotate the elevation knob clockwise, (into the "UP" position). If the shot is high, rotate the elevation knob counter-clockwise. (into the 'L' direction).

If the shot is to the left, rotate the windage knob clockwise, (into the "R" direction). If the shot is to the right, rotate the windage knob counter-clockwise.

## 10. QUICKLOC BARREL REMOVAL AND REPLACEMENT

The AT308 Rifle features the Accuracy International QuickLoc® barrel system as standard.

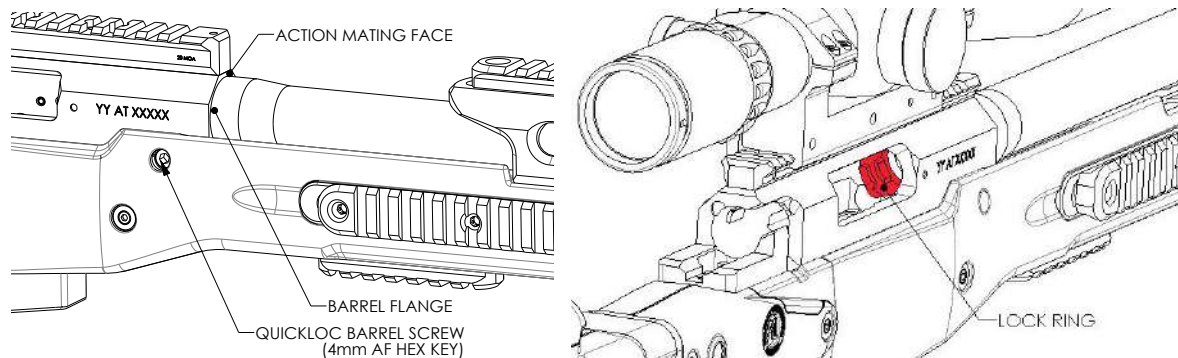

**WARNING**  
**DO NOT REMOVE THE QUICKLOC BARREL SCREW.**  
**DO NOT TIGHTEN THE QUICKLOC BARREL SCREW WITH THE BARREL REMOVED.**

### To Remove the barrel:

- Ensure weapon is safe to handle and unloaded.
- Loosen the QuickLoc® barrel screw 2-3 turns - do not unscrew any further.
- The barrel can now be unscrewed in a anti-clockwise direction. If the barrel will not unscrew by hand, a 3/4" or 19mm AF spanner can be used on the two flats machined into the barrel near the muzzle.

### To Refit the barrel:

- Ensure that the threads and mating surfaces of the barrel and action are clean, undamaged and free of debris.
- Screw the barrel into the action until the action mating face is securely in contact with the barrel flange - no gap should be visible.
- Tighten the QuickLoc® barrel screw to 5.5Nm (49in/lbs).
- Verify that the barrel is tight by trying to unscrew the barrel by hand, using no more than reasonable force.
- Headspace should always be checked after refitting barrels, see section 1.7.



**WARNING - IF THE BARREL CAN BE ROTATED BY HAND AFTER TIGHTENING THE CLAMPING SCREW, RETIGHTEN THE BARREL AND BARREL CLAMPING SCREW AS DESCRIBED ABOVE. IF THIS DOES NOT PROPERLY SECURE THE BARREL, THE RIFLE MUST BE INSPECTED BY AN ACCURACY INTERNATIONAL QUALIFIED GUNSMITH OR ARMOURER.**



**ENSURE THE LOCK RING IS IN PLACE AND IS SECURE. THIS CAN BE INSPECTED THROUGH THE EJECTION PORT.**



## 11. USER LEVEL MAINTENANCE

The rifle has been designed to withstand active service conditions. However, it is necessary to carry out regular maintenance and servicing to ensure the weapon is kept in good condition. This section covers the recommended basic cleaning and lubrication procedures that the user/armourer should perform to maintain the weapon system's safe and accurate functioning.

### 11.1 SAFETY PRECAUTIONS

Before handling or attempting any cleaning or maintenance operations with the rifle, ensure that the rifle is unloaded and safe by carrying out the safety precautions detailed earlier in this manual.

To ensure the rifle is not damaged whilst being cleaned and lubricated, only the recommended tools, cleaning materials and lubricants should be used in accordance with these instructions

No abrasive material should be used on any part of the rifle.

### 11.2 RECOMMENDED LUBRICANTS

The recommend lubricants are listed below; however good quality alternatives may be used if these are not available.

<b>Lubricant</b>	<b>Description</b>	<b>Uses</b>
Break free CLP 16	Cleaner, lubricant & preservative	General cleaning and lubrication of the action and rifle exterior
OX24		
WD40 GT85	Light Penetrating Oil	Lubrication of the trigger
Grease XG 279	General Purpose Lubricating Grease	Hinge, Adjustable Butt Mechanism

### 11.3 RECOMMENDED BORE CLEANERS

<b>Cleaner</b>	<b>Uses</b>
Shooters Choice Bore Cleaner	Copper solvent
Forest Bore Cleaning Foam	Copper solvent
KG 1	Bore Carbon Remover
KG 12	Big Bore Copper Remover
KG SF112	Combined Carbon and Copper Remover

## 11.4 CLEANING & LUBRICATING BEFORE FIRING

Before firing the rifle, it must be cleaned and lubricated as detailed below:

<b>Part</b>	<b>Lubrication Status</b>
Barrel - Exterior	N/A - leave dry
Barrel - Interior (bore and chamber)	Clean and leave dry, see section on “cleaning the barrel and chamber”
Bolt - Front face	Clean and leave dry
Bolt - remaining surfaces	Clean and lightly lubricate with CLP 16 oil or similar
Action Body	Clean and lightly lubricate the inside surfaces with CLP 16 oil or similar
Stock/Chassis	N/A - leave dry

## 11.5 CLEANING & LUBRICATING AFTER FIRING

It is recommended that the barrel be cleaned upon completion of shooting, using the “Cleaning The Barrel & Chamber” procedure described in the next section.

We recommend, as a minimum, that the barrel should be cleaned at the following intervals:

	<b>7.62 x 51mm/.308win</b>
Military Ball Ammunition	Clean after every 100 rounds
Armour Piercing Ammunition	Clean after every 50 rounds

It is also recommend that the bolt body is cleaned and lubricated on a regular basis, i.e. daily when operational or when 100 rounds have been fired.

## 11.6 CLEANING THE BARREL & CHAMBER



**CAUTION:** The suppressor **MUST** be removed before cleaning the barrel.



To avoid damaging the muzzle, the cleaning rod or pull-through must always be inserted from the chamber end.



When cleaning the bore with patches, always work in one direction, chamber to muzzle.  
**DO NOT** pull used patches back through the bore.



Refer to the Bore Solvent Manufacturer's instructions for relevant Health and Safety precautions.  
Solvents must be used sparingly; any excess spillage outside of the barrel must be removed immediately.



Only use the correct size Jag and Phosphor Bronze Brush for the barrel, for example:  
J30 & PB30 for .308



Never use a bore brush in a dry barrel. Always wet the bore with a patch moistened with bore solvent before using a brush.

Note: The bore and chamber are easier to clean after firing, whilst the barrel is still warm.

Where possible, it is recommended that a cleaning rod and a rod guide should always be used when cleaning the barrel. Using a rod guide ensures that the cleaning rod is held in the centre of the bore, which reduces the possibility of damage being caused to the chamber and bore during cleaning. However, care must still be exercised when using the cleaning rod.

The use of a Pull-Through or Bore Snake is not recommended for routine cleaning. If a pull-through is to be used, it must be pulled from the chamber to the muzzle and care must be taken to ensure that the cord is pulled centrally out of the front of the barrel to avoid damaging the crown. The pull-through or bore snake **MUST** be cleaned regularly to remove grit and debris that could damage the bore of the barrel.

If a Pull-Through or Bore Snake has been used, the Barrel should be cleaned using the method defined in this manual, when possible.

## 11.7 CLEANING THE BARREL & CHAMBER

Barrel Cleaning Procedure:

- Unload the rifle and carry out safety precautions.
- Remove the magazine, if fitted.
- Securely hold the rifle horizontally by a suitable means, ideally between the protected jaws of a bench vice, where available.
- Fold the stock.
- Remove the Bolt.
- Remove the Suppressor (if fitted).
- Insert the rod guide into the action body ensuring it has engaged with the bolt catch.
- Ensure the rod is clean before affixing a clean patch to a jag or the patch holder.
- Moisten a patch with Bore Solvent and push it once through the bore (via the rod guide) and the muzzle to wet the bore.
- Remove the soiled patch from the cleaning rod. **DO NOT** attempt to pull the patch back through the bore.
- Remove the jag or the patch holder from the cleaning rod and refit with a correct sized phosphor bronze brush.
- Whilst the bore is still wet, wet the brush with solvent and pass it completely through the bore in each direction several times. Repeat with fresh solvent if necessary. Resistance should be felt when pushing the brush through the barrel. If little resistance is felt the brush may need to be replaced.

**Note:** A conservative recommendation for the necessary number of passes is one pass for every three to four rounds shot.

- Refit the jag or patch holder to the cleaning rod and pass through a clean patch to dry the bore and chamber.
- Remove the patch at the muzzle: **DO NOT** pull it back through the bore.
- Repeat this operation until a new solvent-moistened patch can be passed through the barrel clean (a light grey smudge is acceptable). Once this is achieved, remove any solvent residue with a clean dry patch.

**Note:** Where the rifle is to be stored for a lengthy period or when in a corrosive atmosphere, a thin smear of oil should be left in the bore.

- Moisten a patch with CLP 16 oil and pass it once through the bore. (this must be removed before shooting).

The chamber is to be cleaned using a chamber cleaning brush or a screw-on chamber brush and one of the cleaning rod sections. Always pass a dry patch through the bore after cleaning the chamber to remove any debris or cleaning product residue.

Wipe away all surplus solvents from inside the Action Body and from the Muzzle Brake.

## 11.8 REMOVING HEAVY COPPER AND CARBON FOULING

- Whilst it is not necessary to carry out the following procedure each time the barrel is cleaned, it should be followed when a high number of rounds has been shot.
- Heavy copper fouling may be seen from the muzzle as a copper coloured residue, carbon fouling will be seen as a black residue between the lands. The heaviest fouling tends to occur within 12" (300mm) of the chamber.
- It is important to remove fouling deposits as it increases the pressure within the barrel resulting in hard extractions, loss of accuracy and potentially making the rifle unsafe to use.
- For optimal results, it is recommended that a copper solvent and a carbon remover be used alternately to clean a heavily fouled barrel, (see "Recognized Lubricants & Bore Solvents" table).
- Refer to the Copper/Carbon Solvent Manufacturer's instructions to determine how the solvent should be applied to the bore and how long it should be left to penetrate the fouling.
- After the Copper/Carbon Solvent has been left to penetrate the fouling for the recommended time, insert the rod guide into the action body ensuring it has engaged with the bolt catch.
- Fit the correct sized phosphor bronze brush to the rod and pass through the barrel several times in each direction. Resistance should be felt when pushing the brush through the barrel. If little resistance is felt the brush may need to be replaced.
- Fit the jag or patch holder to the cleaning rod and pass through a clean patch to dry the bore and chamber.
- Remove the patch at the muzzle: DO NOT pull it back through the bore.
- If alternating between carbon and copper solvents, repeat the cleaning procedure again with the alternative product, leaving it to penetrate the fouling for the recommended time.
- Repeat this operation until a new solvent-moistened patch can be passed through the barrel clean (a light grey smudge is acceptable). Once this is achieved, remove any solvent residue with a clean, dry, patch.
- Wipe away all surplus solvents from inside the Action Body and from the Muzzle Brake.

Note: The presence of carbon and copper fouling in the barrel often shows as a coloured residue on cleaning patches. This colour varies from one cleaning product to the next e.g. heavy copper fouling may show as blue on the patch, heavy carbon fouling may show as grey on the patch. Check your specific cleaning product for guidance and repeat the cleaning procedure above, as necessary, until the patches come out clean.

Note: It may be necessary to reapply the solvent and repeat this process to completely remove stubborn deposits.

## 11.9 GENERAL RIFLE CLEANING

The action body should be brushed clean to remove any brass particles or dirt. The rest of the rifle should be wiped or brushed down until clean.

Ancillary items such as magazines and bipods should be brushed clean and lightly oiled if required.

If working in a wet environment or the weapon is to be put into storage, parts should be lightly oiled using CLP 16 or similar.

## 11.10 CLEANING THE TACTICAL SUPPRESSOR

It is important that deposits of carbon are removed through the suppressor and muzzle break, as a build up can make it more difficult to fit and remove the suppressor.

Apply Break Free CLP to the muzzle location in the suppressor and onto the suppressor itself. Leave the CLP to penetrate and remove the carbon with a small stiff brush and cloth.

Using a cloth, wipe dry the inside of the muzzle brake internal location diameter and thread, in the rear of the suppressor.

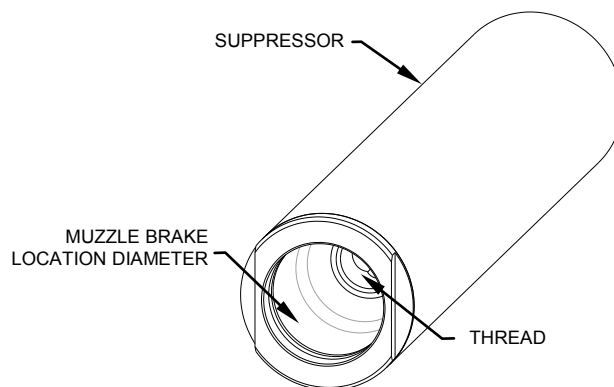

## **12. BARREL BREAK-IN PROCEDURE**

Before a new rifle reaches a customer it has been already shot several rounds. The rifle is first 'proof' tested and then tested for function and accuracy by firing at least two five-round groups. The rifle and barrel are cleaned thoroughly after each of these processes.

If the user wishes to continue a barrel break in procedure on the receipt of the new rifle, we would suggest the following, using standard ball ammunition. The barrel cleaning procedure described in this manual should be followed while carrying out any barrel breaking in procedure.

Shoot 3 shots and clean  
Shoot 5 shots and clean  
Shoot 5 shots and clean  
Shoot 10 shots and clean

It is important to maintain a good cleaning regime for the life of the rifle.